

HS3-(3K-12K)-T2-(W, G)-(B, P)X Quick Guide

This quick guide provides installation operations and product datasheets. For safety precautions and detailed product information, refer to the *User Manual* on the SAJ Website www.saj-electric.com. You can scan the below QR code to access all the product documentation.



NOTICE

- Before installation, operation, and maintenance, read the product documentation carefully.
- ONLY qualified and trained electricians who have read and fully understood all safety regulations contained in this manual can install, maintain, and repair the equipment. The operation personnel should understand the system, its working principles, and relevant national and regional standards.
- During operations, wear protective equipment and use dedicated tools.

1. Check the outer packing

1. Check the outer packing package for any damage, such as holes and cracks.
2. Check the equipment model.

If any serious damage is found or the model is not what you requested, do not unpack the product, and contact your dealer as soon as possible.

2. Check the product packages

Place the connectors separately after unpacking to avoid confusion for connection of cables.

HS3 inverter

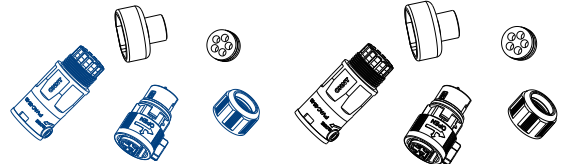
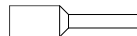
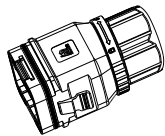
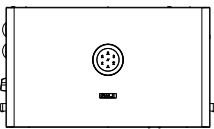

Inverter

24-pin communication cable connector

Insulated terminals x22

Backup load connector (blue) kit

Grid connector (black) kit

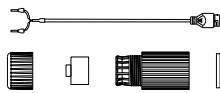
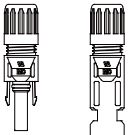

PV connector x4

Communication cable kit

¹ Meter kit

Printed documents

¹The meter kit contains the following items:

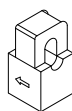
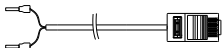

Communication cable with an RJ45 connector

Smart meter

Current transformer x3 (optional)

BU3 battery pack—Type A

Type A battery has two holes on the left and right sides.

- Battery pack with a base (BU3-5.0-(TV1, TV2)-BASE or BU3-5.0-(TV1, TV2)-PRO-BASE)

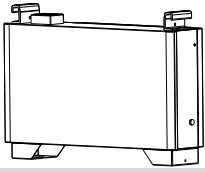

Battery module

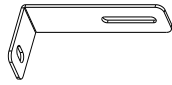

Locking bracket x2

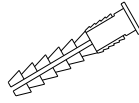

M6*80 expansion bolt x2

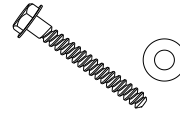

M6*50 screw x2
Gasket x2

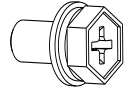

M5*14 screw x4

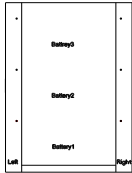

Cardboard

- (Optional) Battery without a base (BU3-5.0-(TV1, TV2) or BU3-5.0-(TV1, TV2)-PRO)

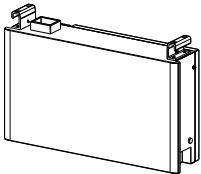

Battery module

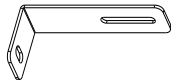

Locking bracket x2

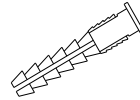

M6*80 expansion bolt x2

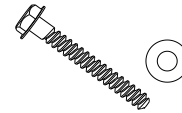

M6*50 screw x2
Gasket x2

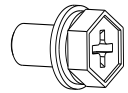

M5*14 screw x4

BU3 battery pack—Type B

Type B battery pack has two mounting ears on the rear cover.

- Battery pack with a base (BU3-5.0-(TV1, TV2)-BASE or BU3-5.0-(TV1, TV2)-PRO-BASE)

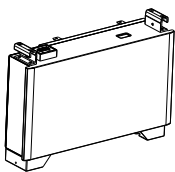

Battery module



Locking bracket x2

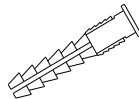

M6*80 expansion bolt x2

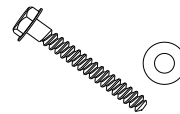

M6*50 screw x2
Gasket x2

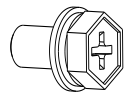

M5*14 screw x4

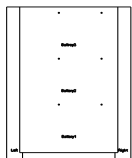

Cardboard



M4*12 screw
(For Australia)



Grounding plate
(For Australia)

- (Optional) Battery without a base (BU3-5.0-(TV1, TV2) or BU3-5.0-(TV1, TV2)-PRO)

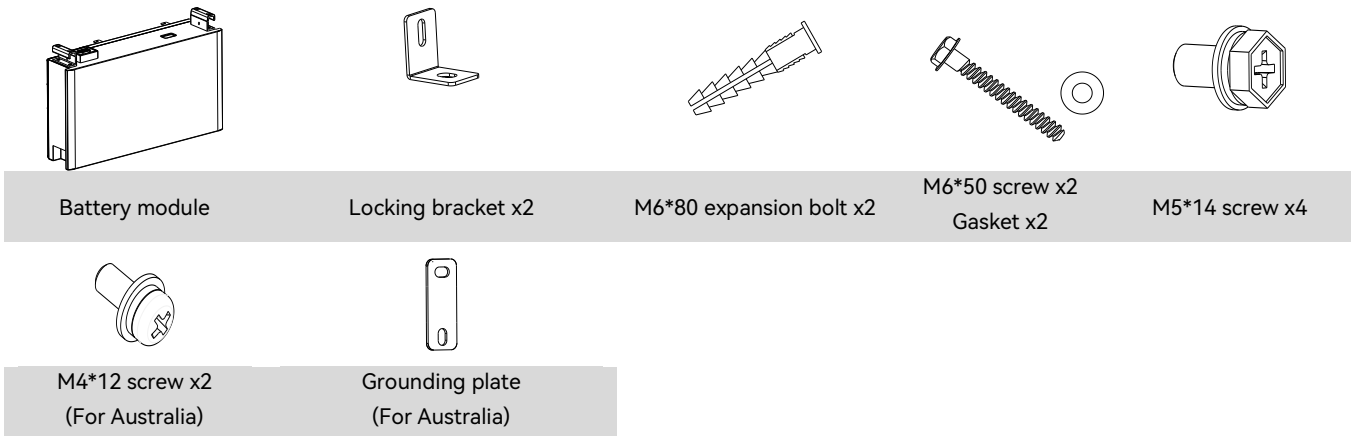

BT3 wall-mounting bracket (optional)

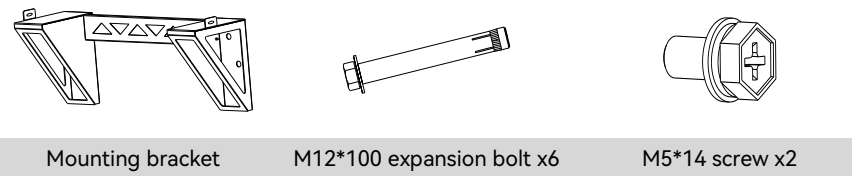

BC3 battery junction box (optional)

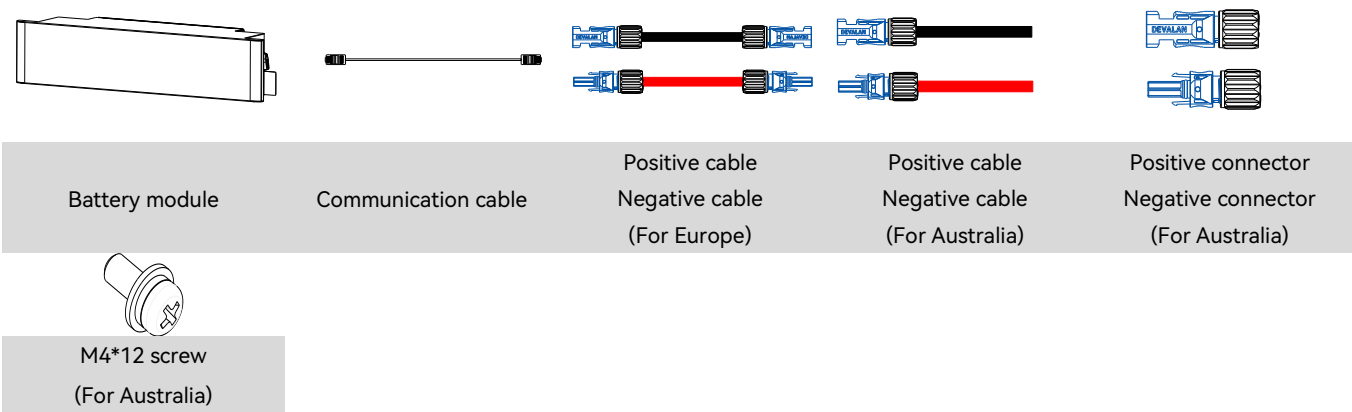

CU2 charger (optional)

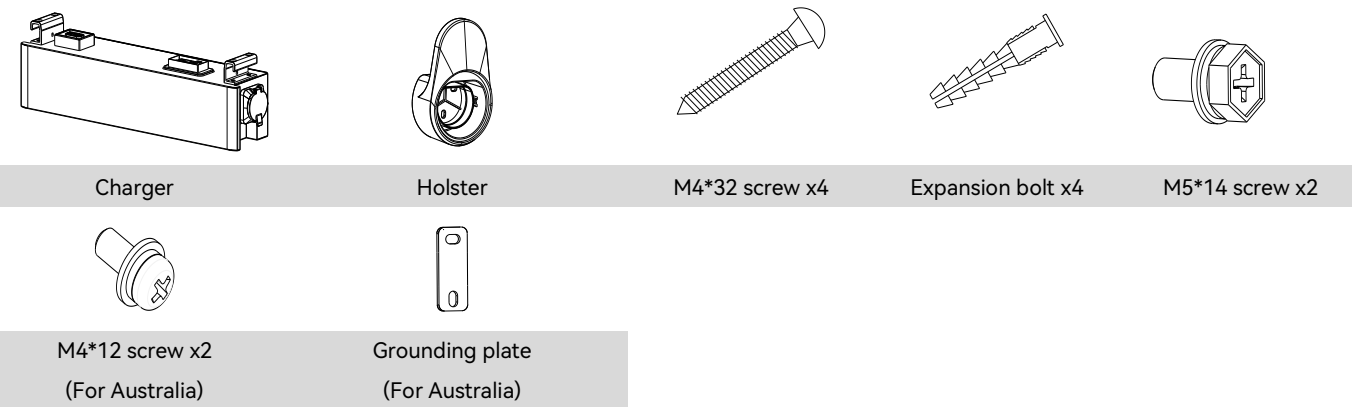

3. Check installation ways and gaps

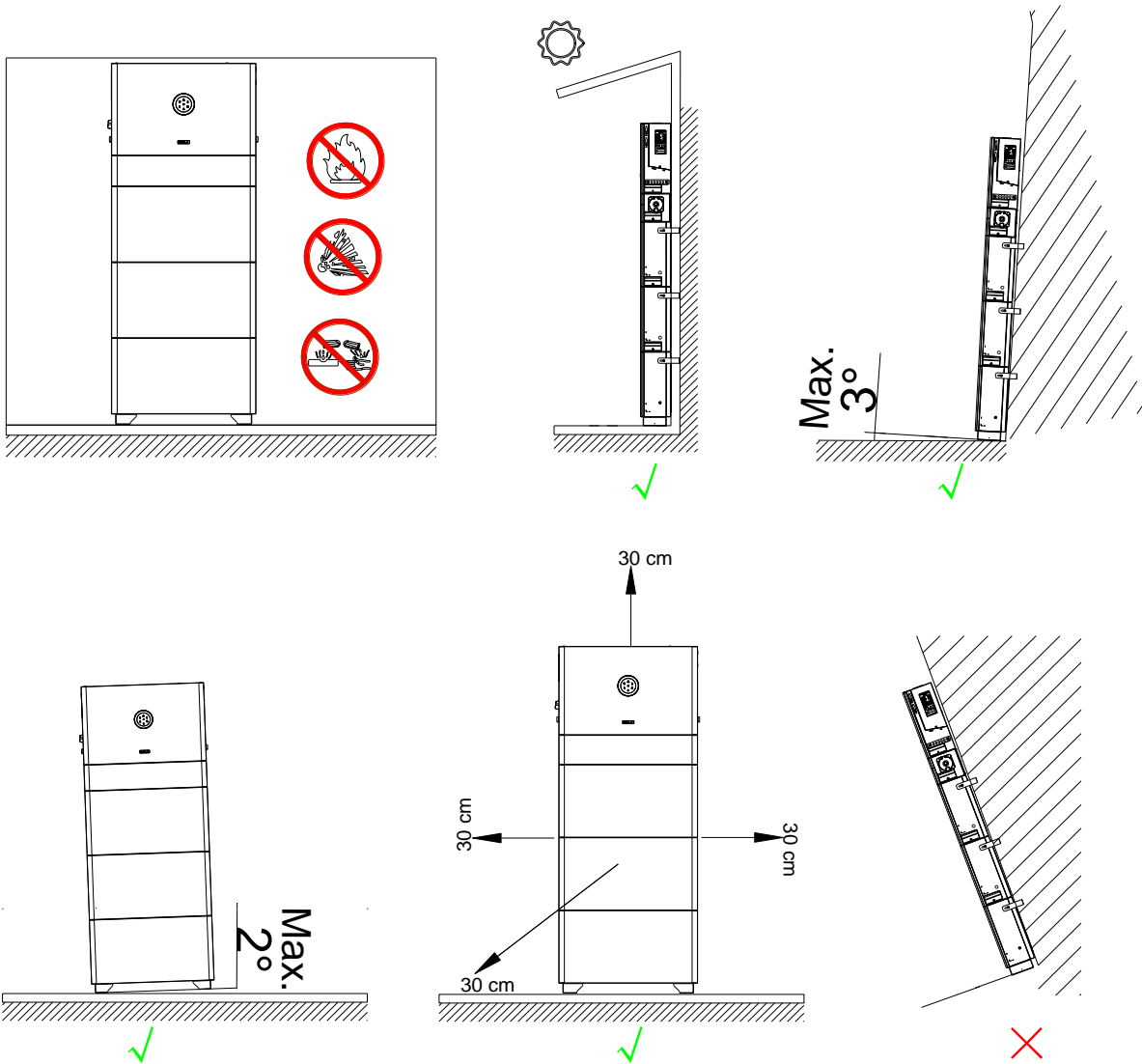

Depending on the battery pack type (A or B) and mounting manner, choose the following installation procedure:

- Type A battery pack in the ground-mounting manner: Step 4
- Type B battery pack in the ground-mounting manner: Step 5
- Type B battery pack in the wall-mounting manner: Step 6

4. Install type A battery pack: grounding manner

4.1. Install the base battery (BU3-5.0-(TV1, TV2)-BASE or BU3-5.0-(TV1, TV2)-PRO-BASE)

1. Place the cardboard on to the wall. Drill six holes (8 mm in diameter and 55 mm in depth) on the marked positions on the cardboard. Install the provided expansion bolts into the drilled holes.

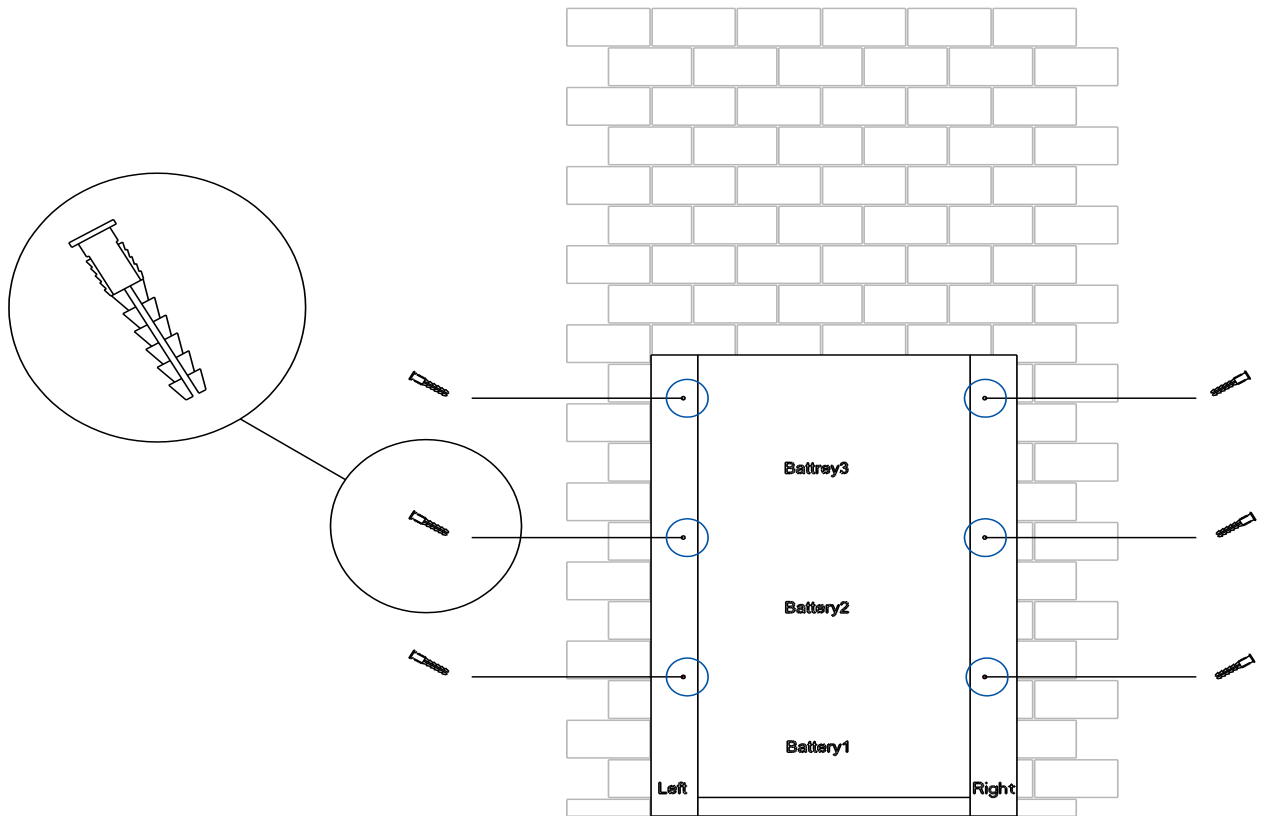
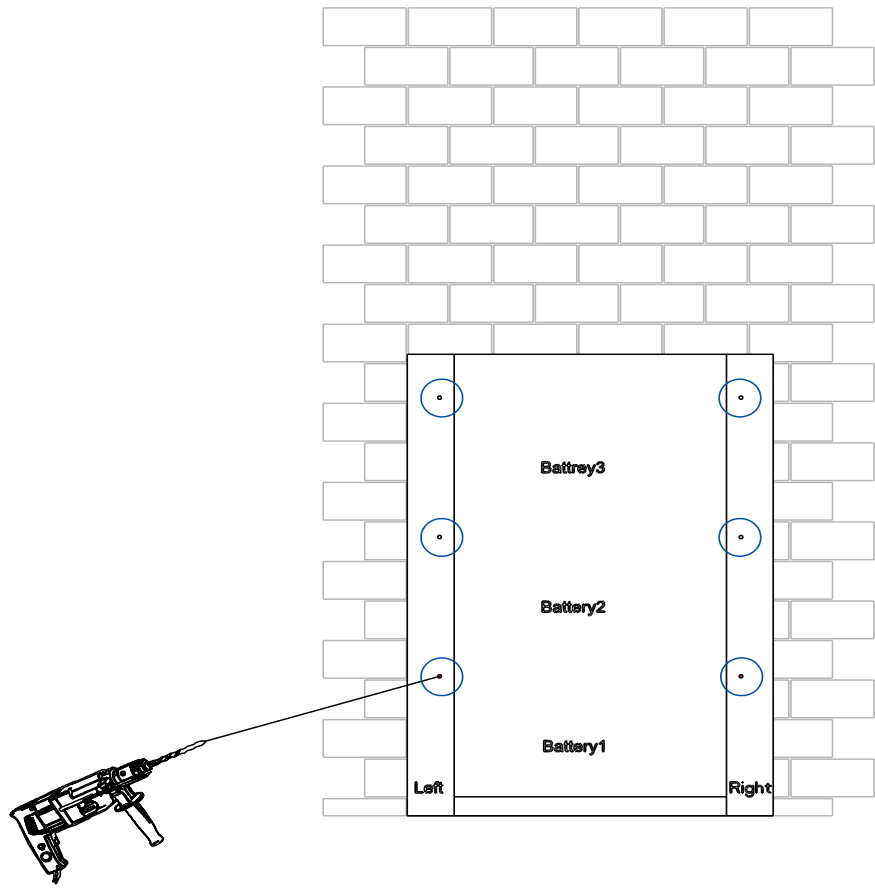

2. Use two M5*14 screws to install two locking brackets on both upper sides of the battery. Place the base battery onto the floor. Make sure that:
- The battery feet are aligned with the vertical black line on the cardboard.
 - It is recommended to use a gradienter to make sure that the battery is placed horizontally.
 - The space between the battery back and the wall surface is 50–65 mm.

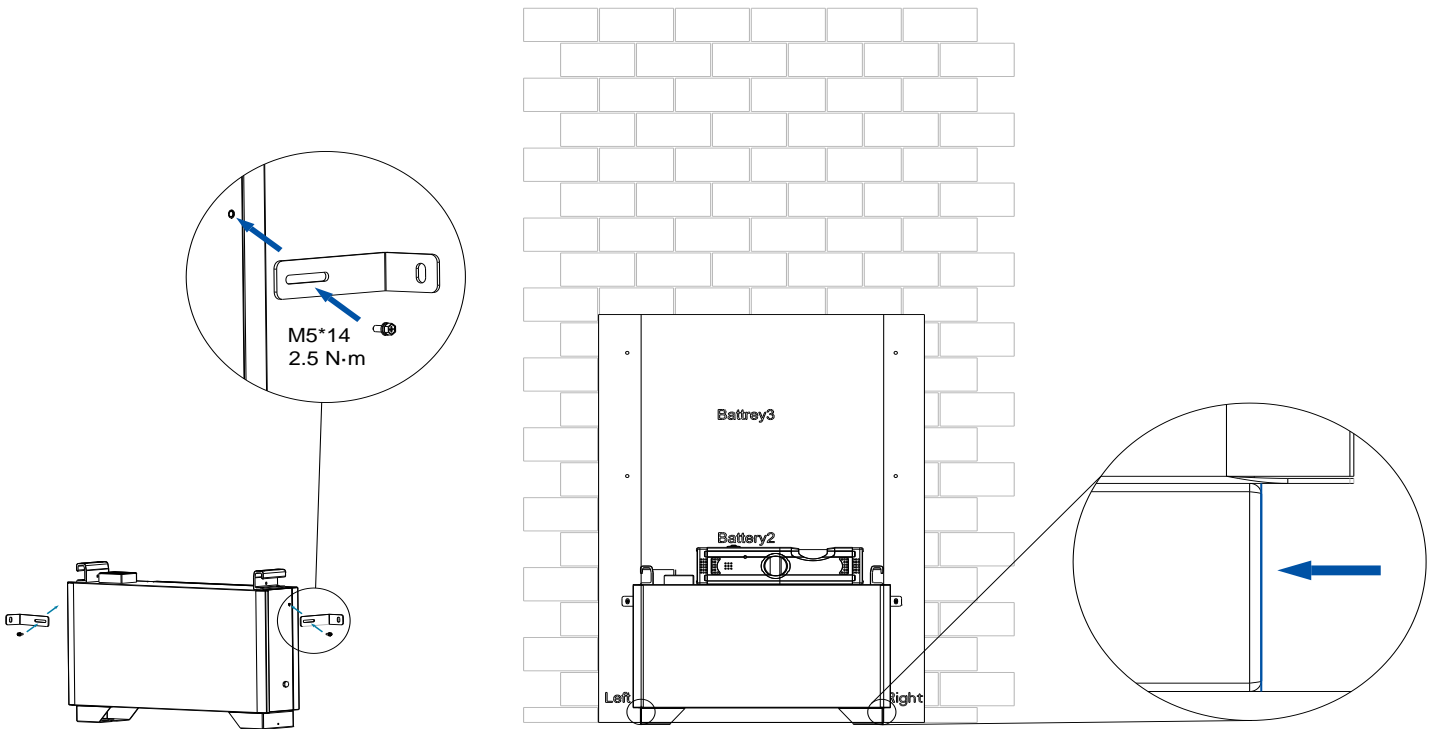

3. Align the locking brackets to the drill holes and install M6*50 screws to secure the locking brackets to the wall.
- Note:** If the battery is installed outdoors, it is suggested to remove the cardboard which is not waterproof.

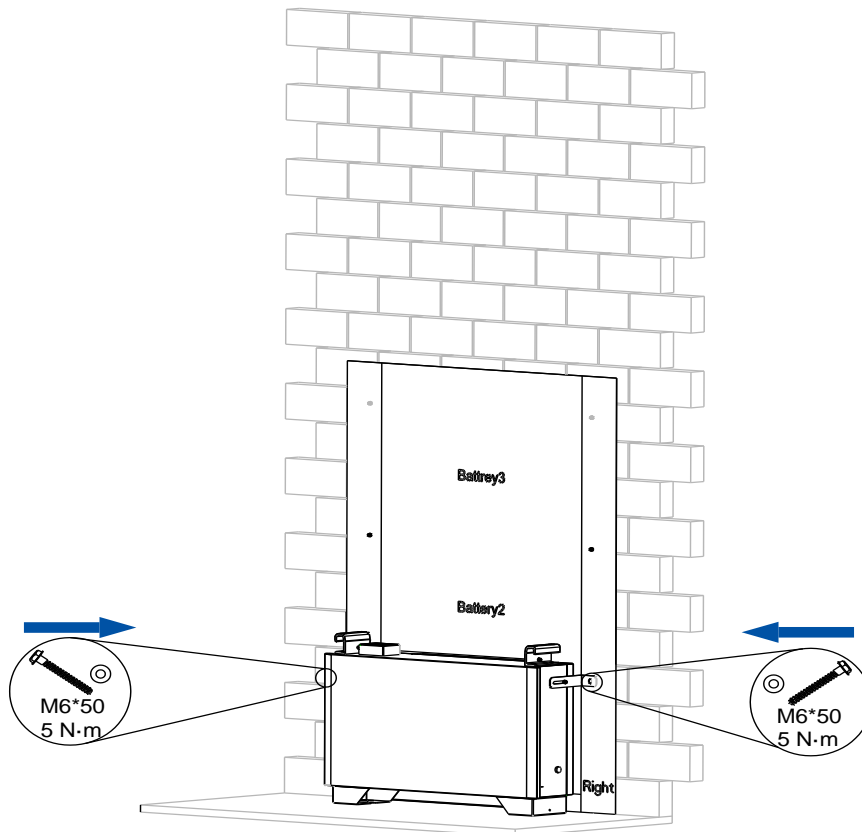

4.2. (Optional) Install other batteries (BU3-5.0-(TV1, TV2) or BU3-5.0-(TV1, TV2)-PRO)

- Use two M5*14 screws to install two locking brackets on both upper sides of the battery. Place this battery onto the base battery. Push it downwards.

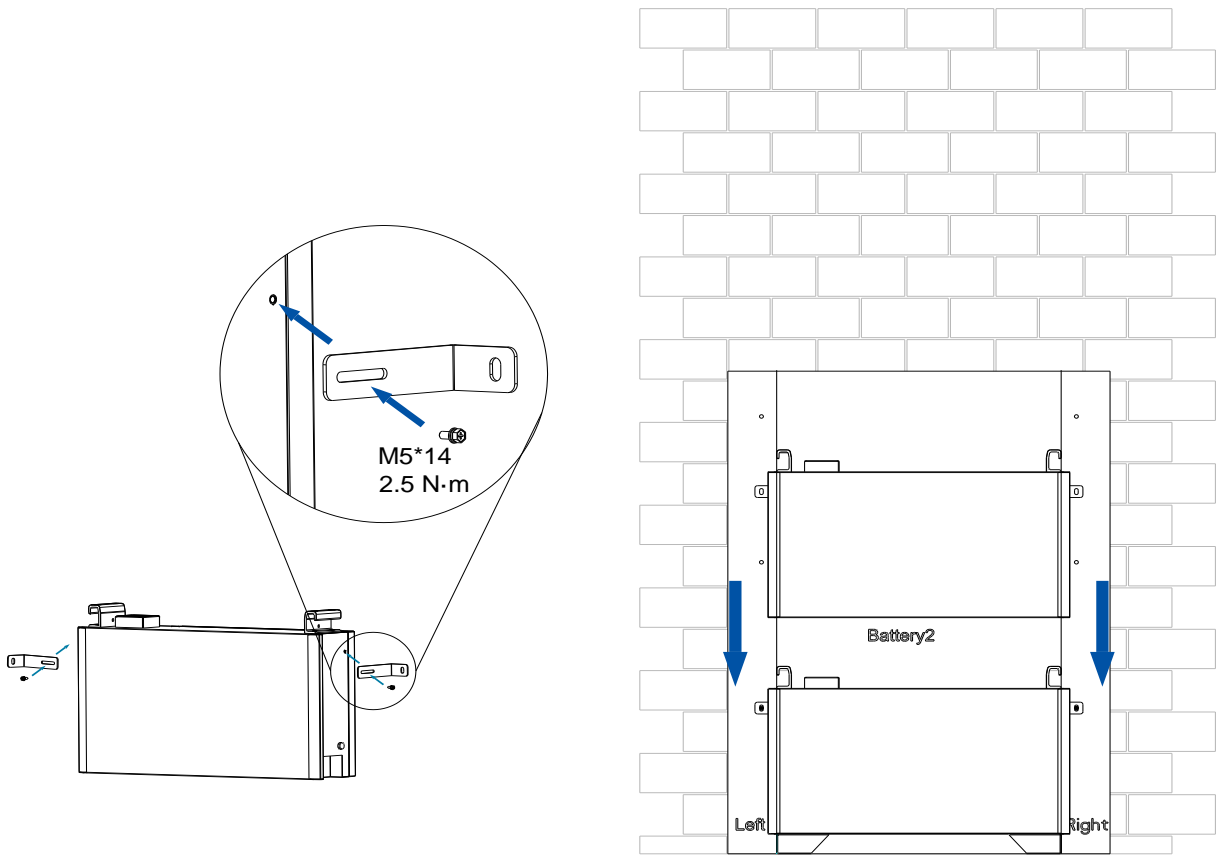

- On each lower side of the battery: Install two M5*14 screws to secure two batteries.
On each upper side of the battery: Align the locking bracket to the drill hole and install the gasket and M6*50 screw to secure the locking brackets to the wall.

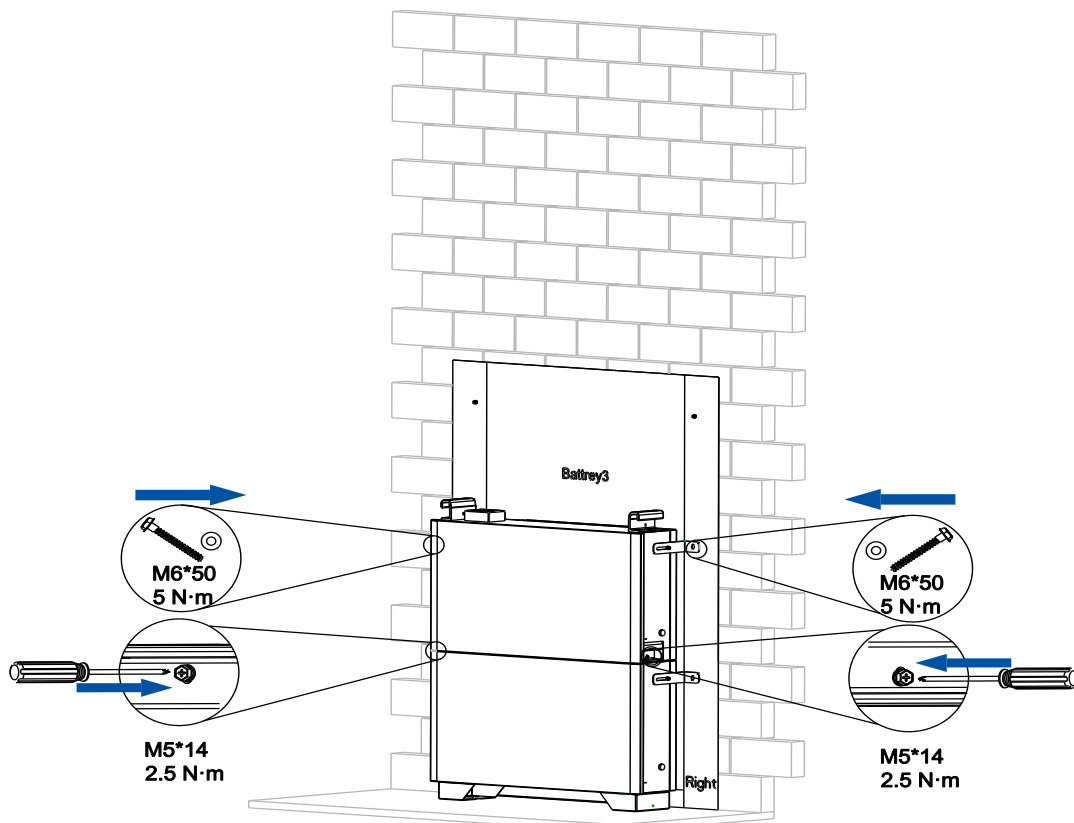

3. (Optional) If needed, repeat steps 1 and 2 to install the third battery.

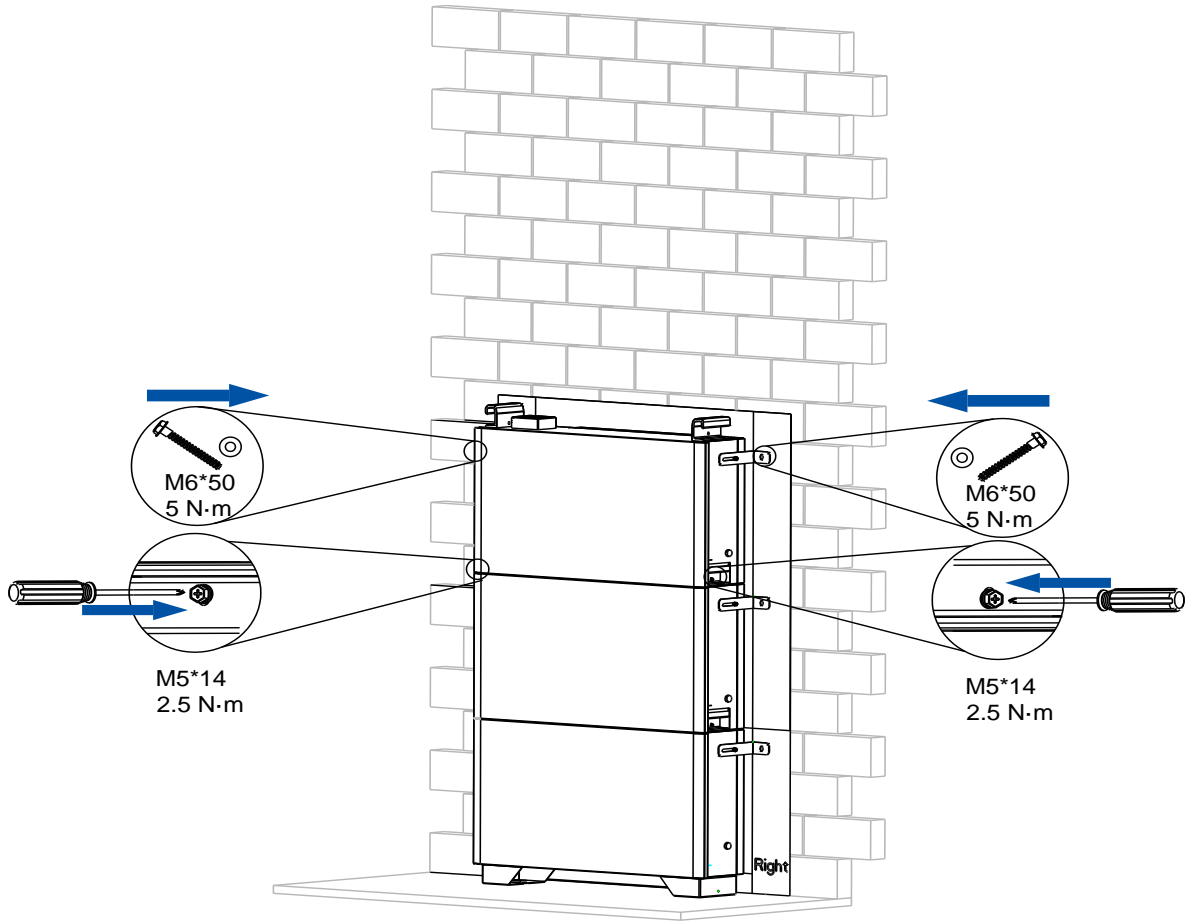

4.3. (Optional) Install the charger (CU2-11K-T-I)

1. Get the holster from the charger package. Install the holster onto the right side of the charger.
2. Place the charger onto the battery. Push it downwards.
3. Install M5*14 screws on both lower sides of the charger to secure the charger to the battery.

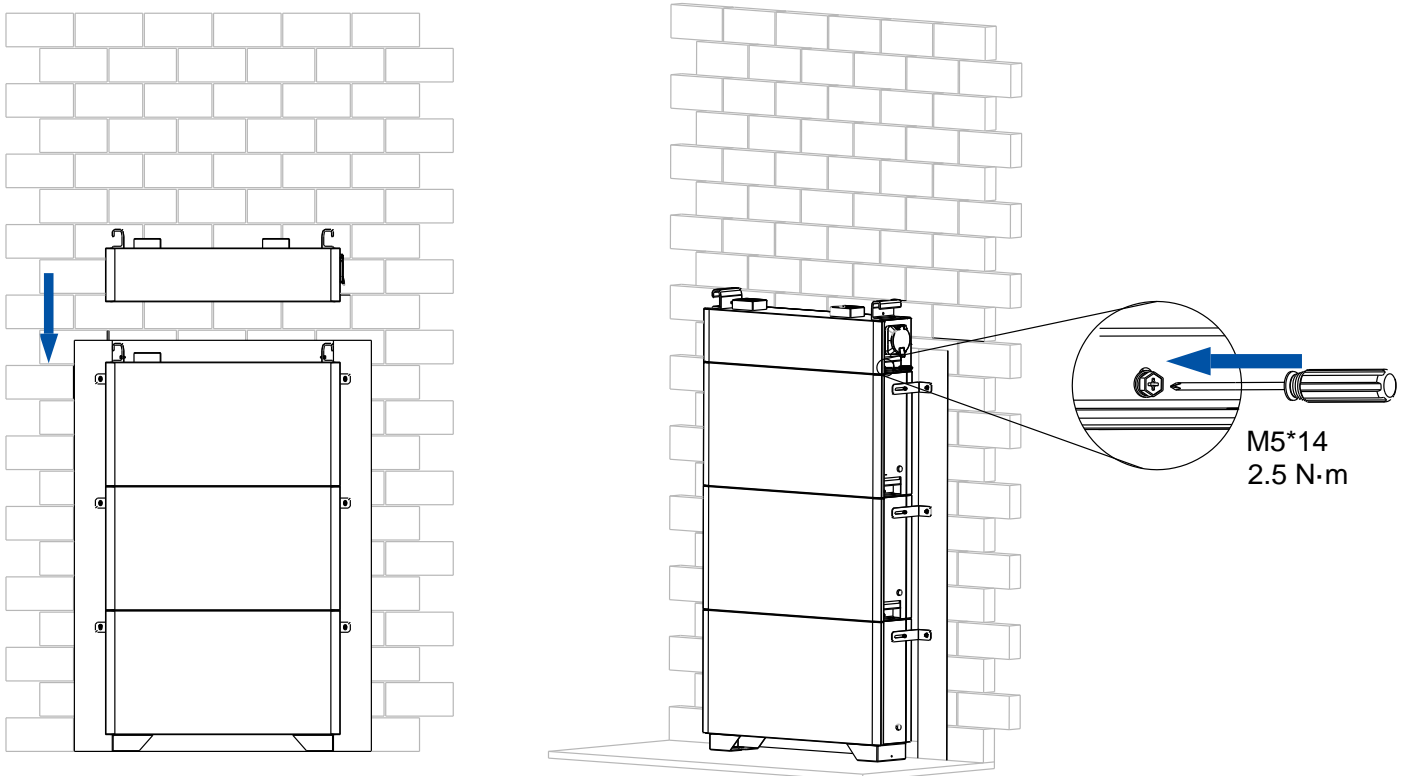

4. Install the holster on the wall by using three M4*32 screws.

Note: The holster is used to secure the charger cable. You can connect the cable after all installation is completed. It is recommended that you purchase the cable from SAJ.

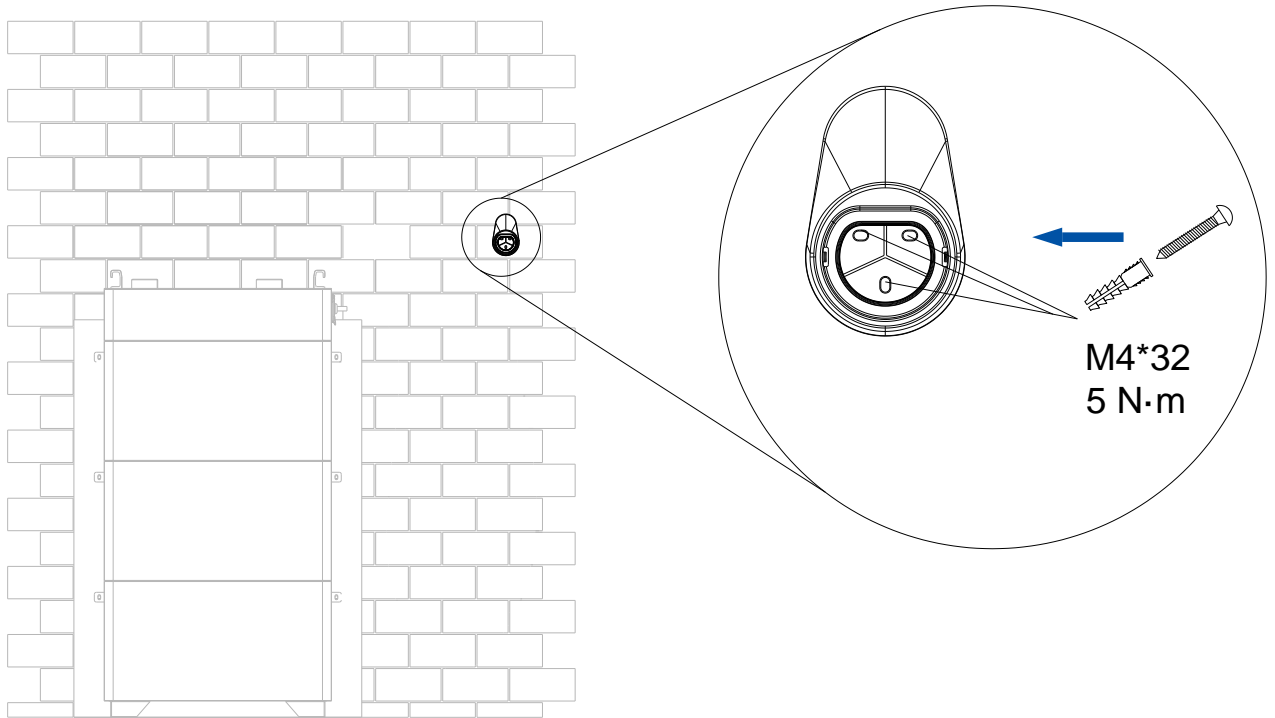

4.4. Install the inverter (HS3-xk-T2-(W, G)-(B, P) or HS3-xK-T2-(W, G)-(B, P)-(BE, IE))

1. (Optional) If you have installed a charger, loosen the screws on the inverter, and remove the port cover, as shown below:

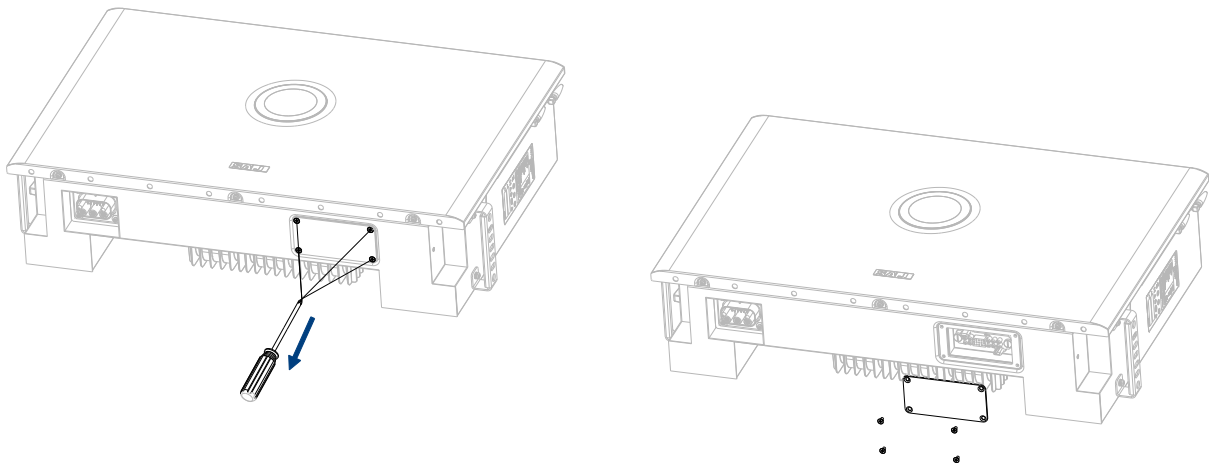

- Place the inverter onto the battery or charger (if available). Push it downwards. Install screws on both lower sides of the inverter to secure the inverter to the beneath device (battery or charger; here takes a charger as an example).

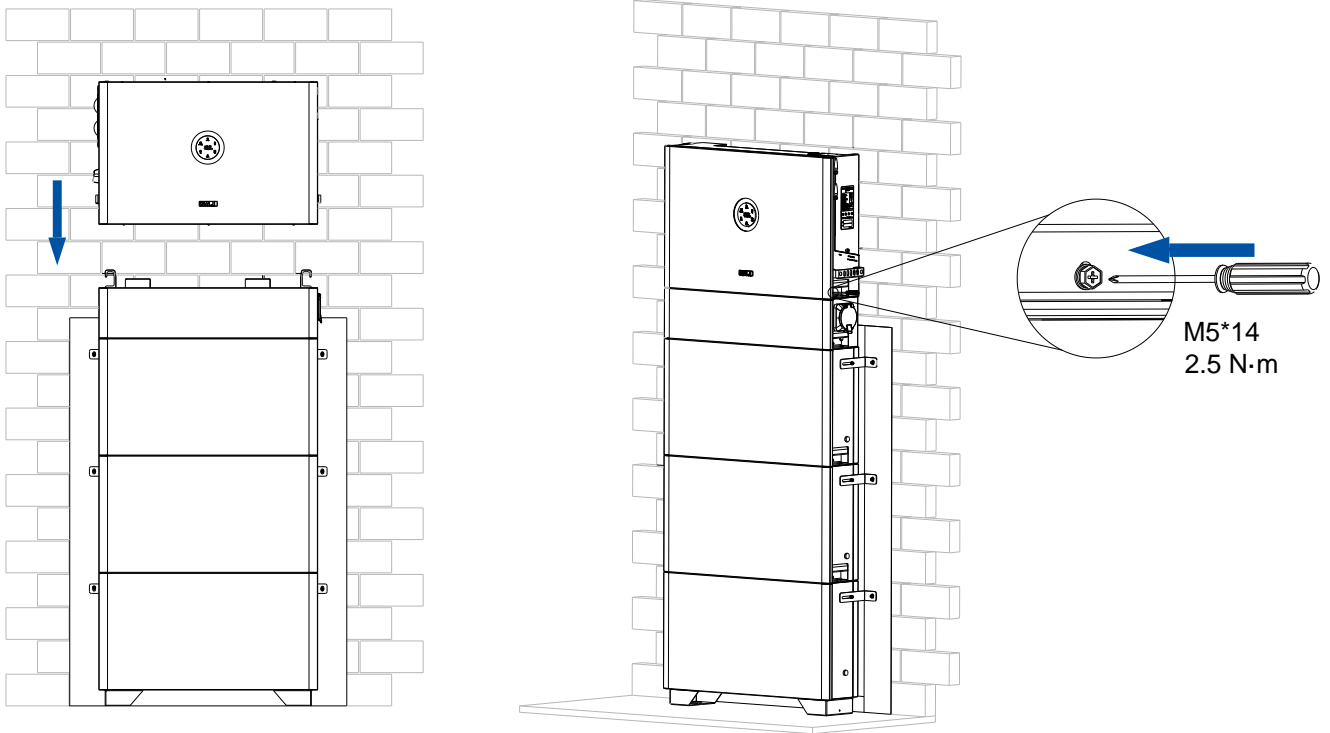

Completion View

Example of 3 batteries:

Inverter + charger + batteries

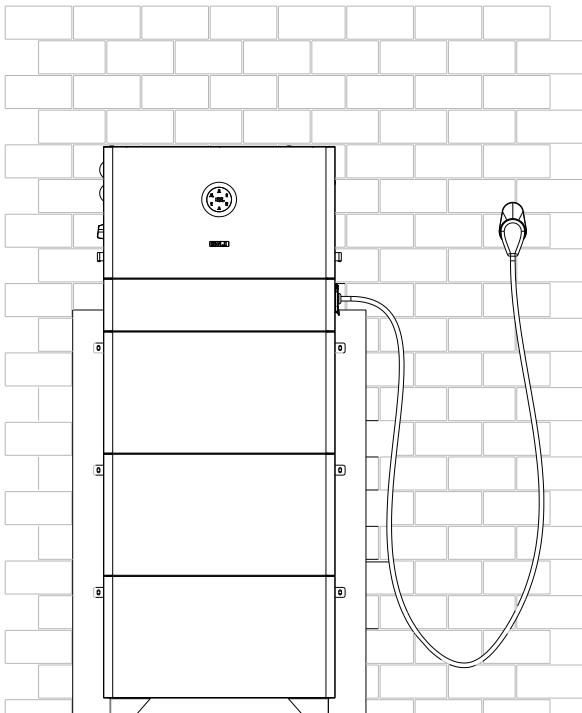

Inverter + batteries

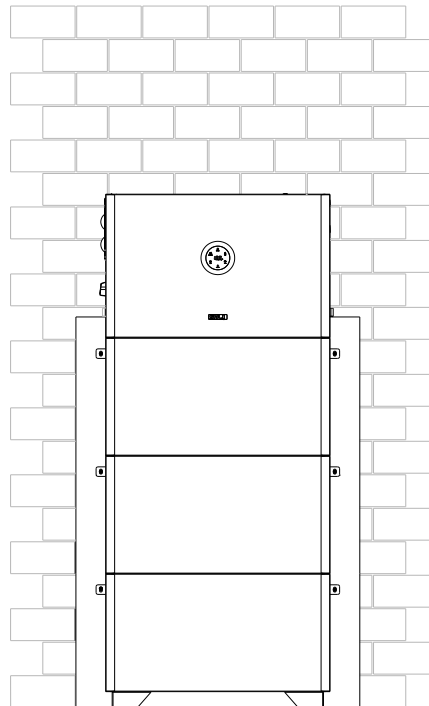

□ 5. Install type B battery pack: grounding manner

5.1. Install the base battery (BU3-5.0-(TV1, TV2)-BASE or BU3-5.0-(TV1, TV2)-PRO-BASE)

1. Get the cardboard from the base battery package. Place the cardboard on to the wall. Drill six holes (8mm in diameter and 55mm in depth) on the marked positions on the cardboard. Install the provided expansion bolts into the drilled holes.

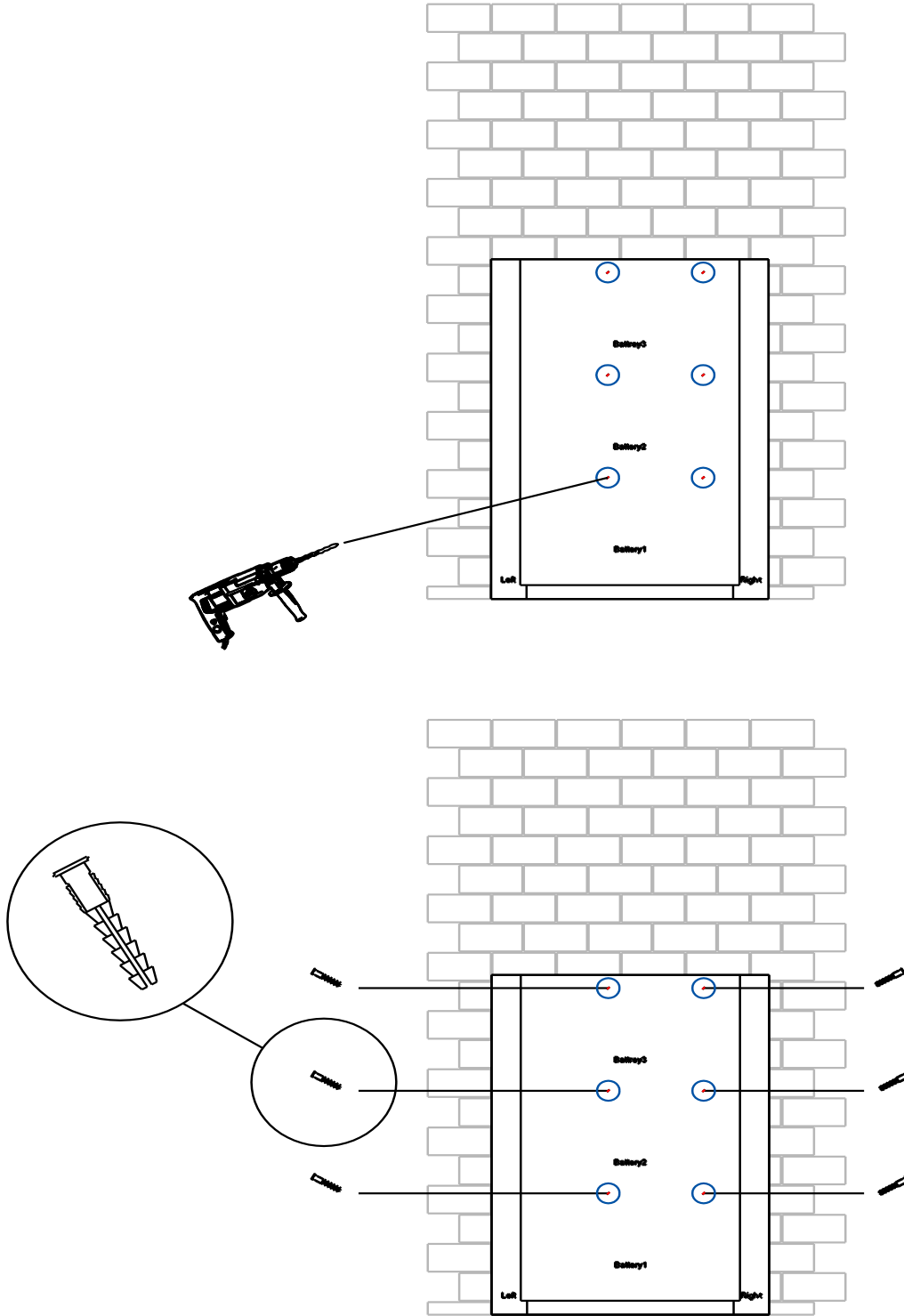

2. Use two M5*14 screws to install two locking brackets to the mounting ears on the top of the battery pack. On the desired installation site, place the base battery on the floor. Make sure that:
 - The left and right battery bases are aligned with the vertical black lines on the cardboard.
 - The battery pack is placed horizontally. (It is recommended that a gradienter be used.)
 - The space between the battery back and the wall surface is 40–50 mm.

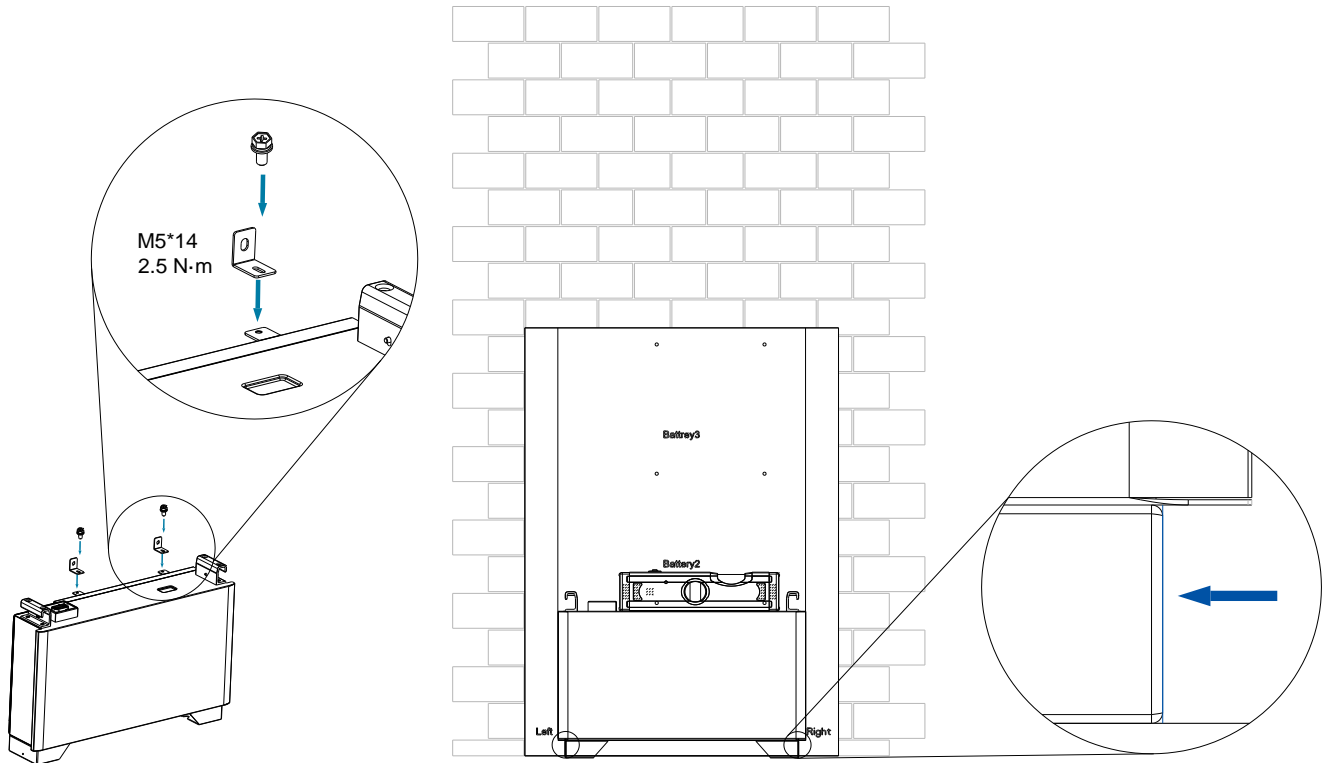

3. On the top of the battery pack, align the locking brackets to the drilled holes and install M6*50 screws to secure the locking brackets to the wall.

Note: If the battery is installed outdoors, it is suggested to remove the cardboard which is not waterproof.

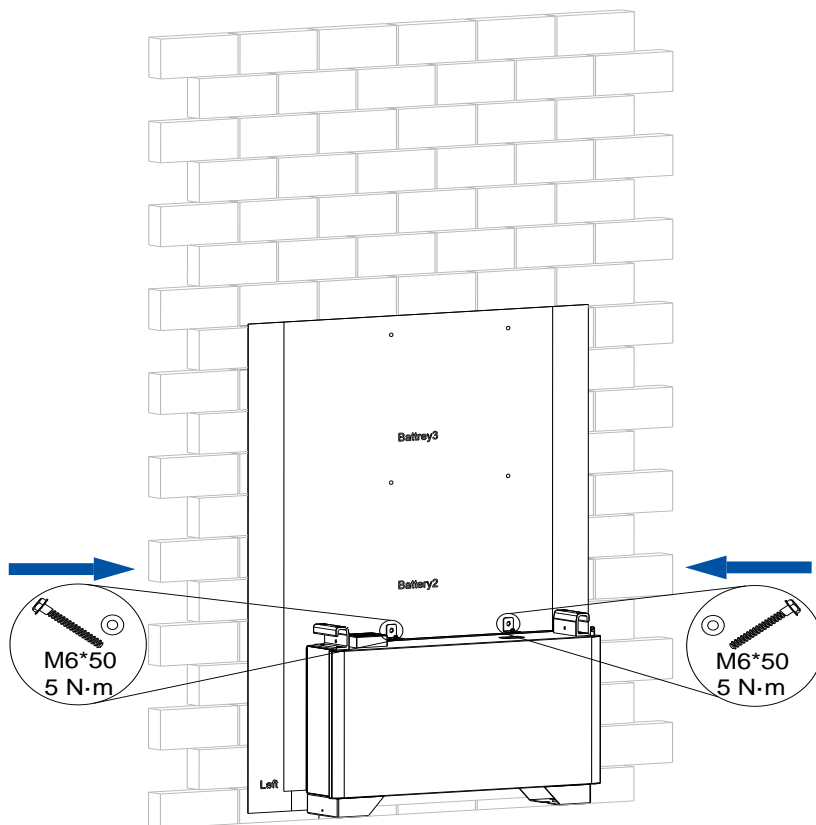

5.2. (Optional) Install other batteries (BU3-5.0-(TV1, TV2) or BU3-5.0-(TV1, TV2)-PRO)

Note: In one stack, up to three batteries are supported.

1. Use two M5*14 screws to install two locking brackets to the mounting ears on the top of the battery pack. Place this battery onto the base battery and push it downwards.

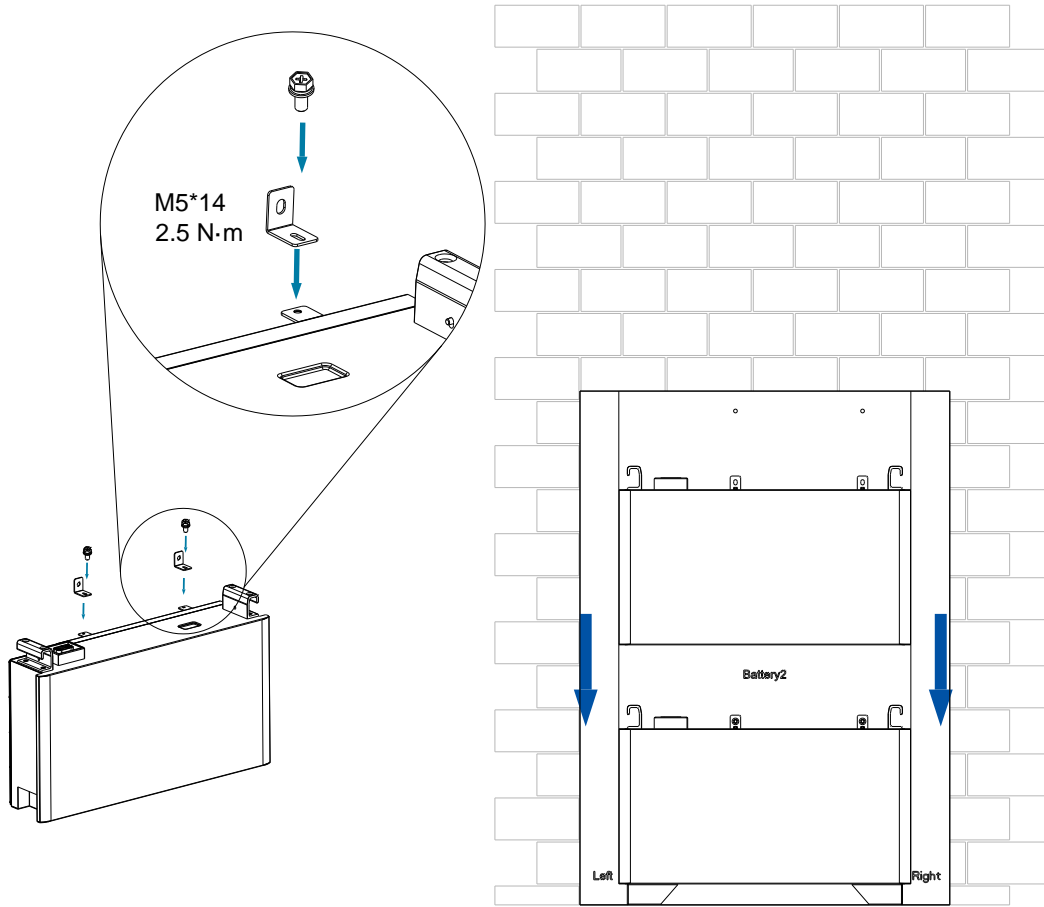

2. On the top of the battery pack, align the locking brackets to the drilled holes and install the gaskets and M6*50 screws to secure the battery pack to the wall.

On the left and right bottom sides of the battery pack, install M5*14 screws to secure two batteries.

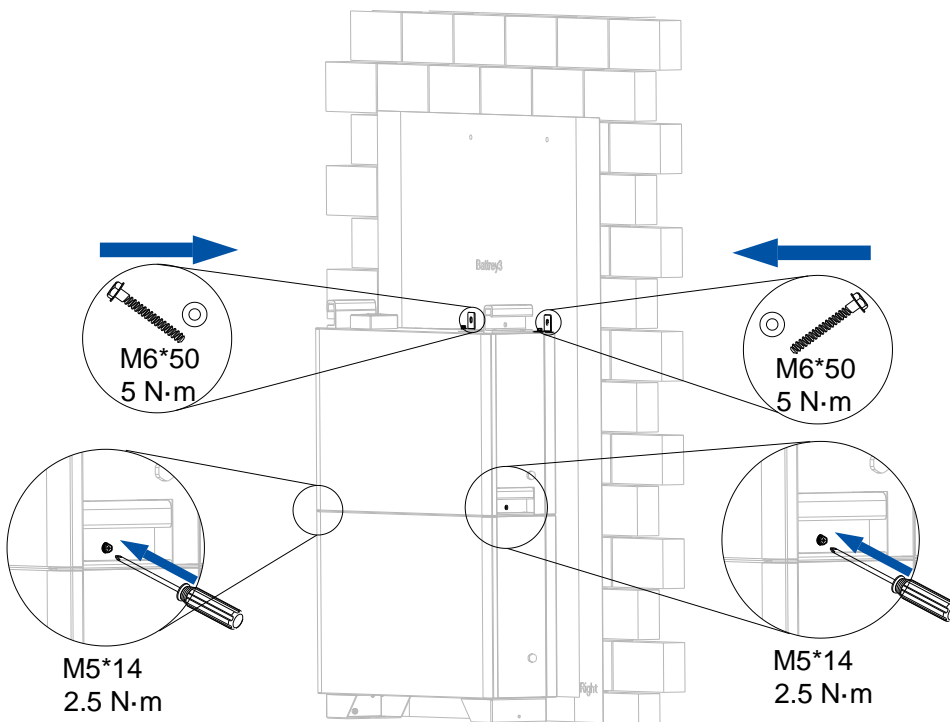

Australia only: As shown below, install the metal grounding plate and secure it by installing two M4*12 screws.

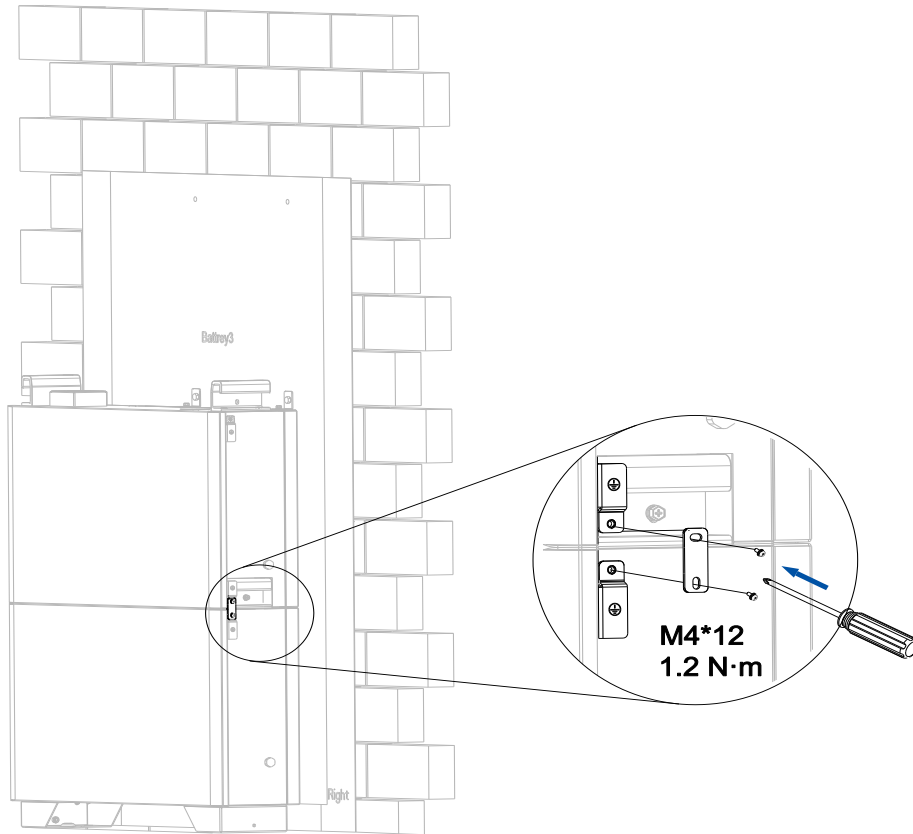

3. (Optional) If needed, repeat steps 1 and 2 to install the third battery.

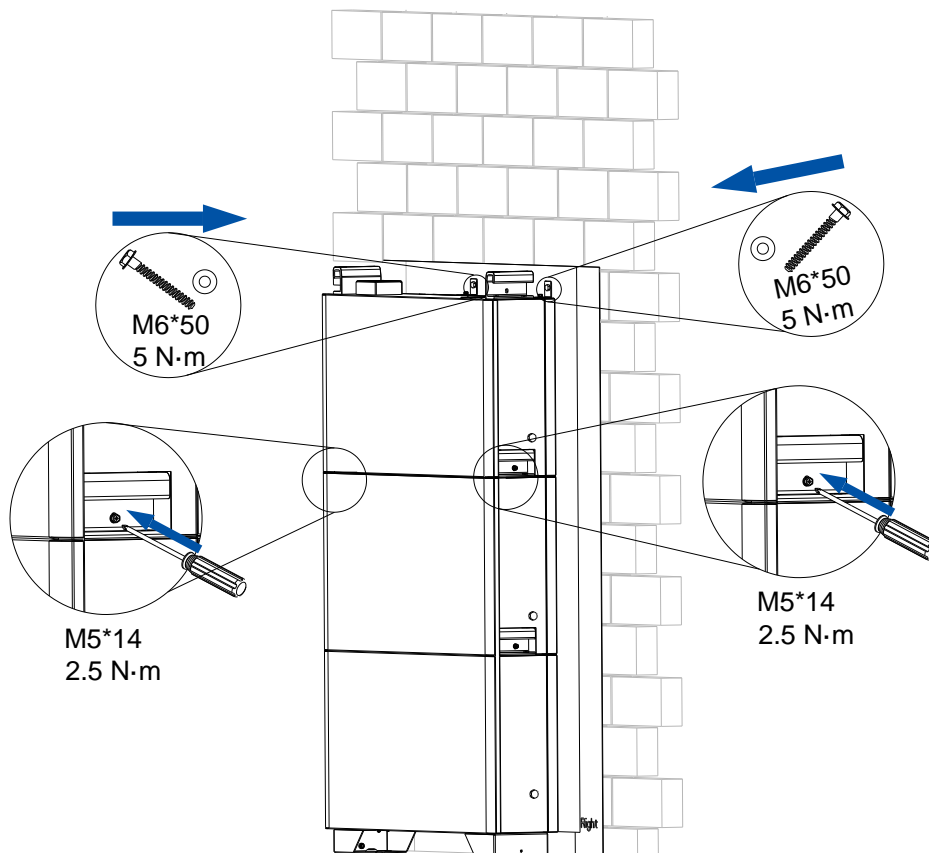

Australia only: As shown below, install the metal grounding plate and secure it by installing two M4*12 screws.

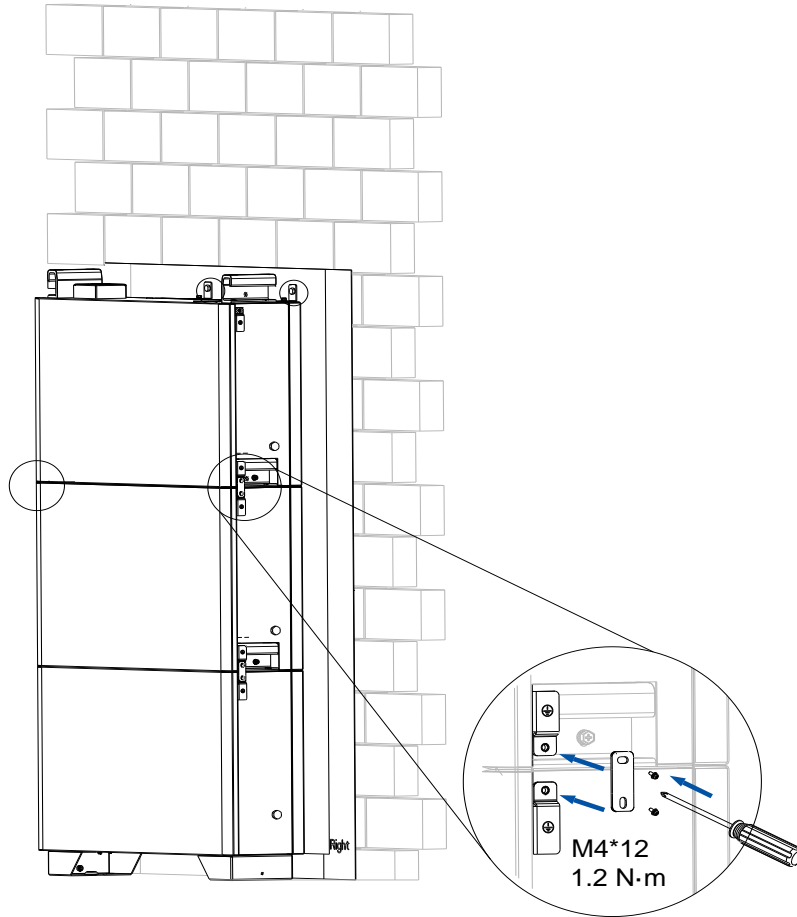

5.3. (Optional) Install the charger (CU2-11K-T-I)

1. Get the holster from the EV charger package. Install the holster onto the right side of the charger.
2. Place the charger onto the battery. Push it downwards.
3. On the left and right bottom sides, install M5*14 screws to secure the charger to the battery.

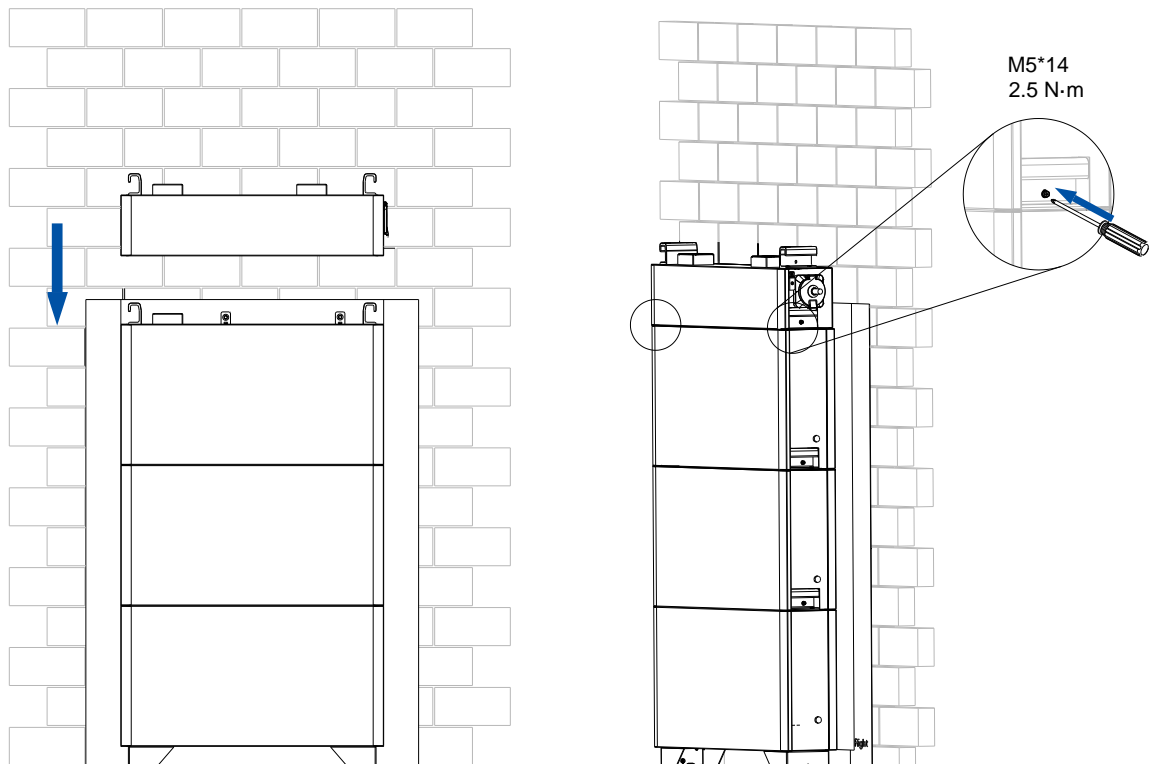

Australia only: As shown below, install the metal grounding plate and secure it by installing two M4*12 screws.

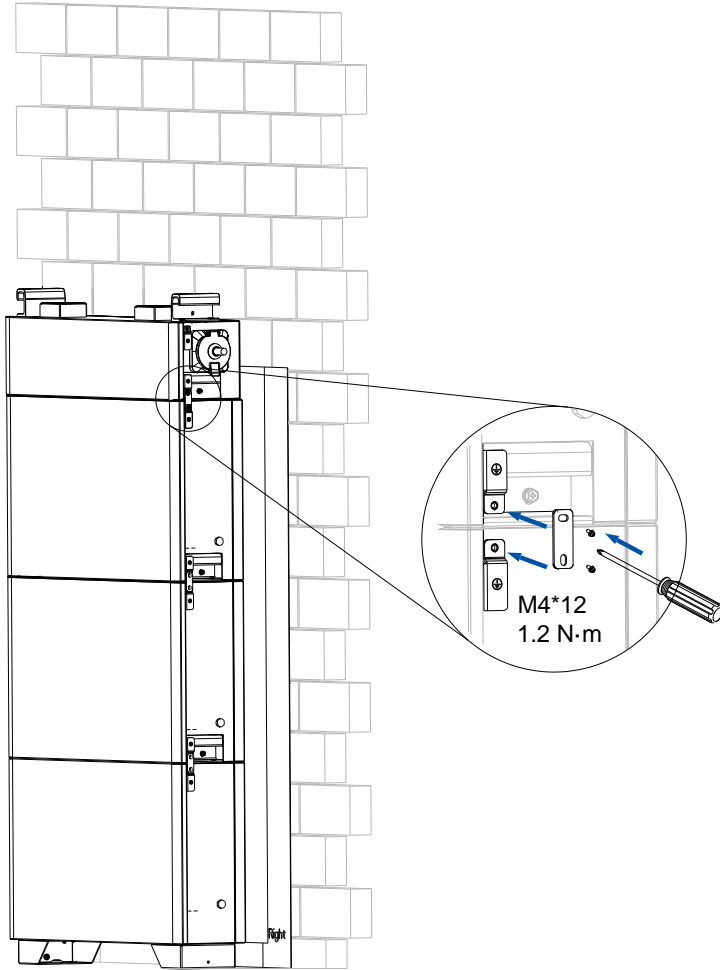

4. Install the holster on the wall by using three M4*32 screws.

Note: The holster is used to the charger cable. You can connect the cable after all installation is completed. It is recommended that you purchase the cable from SAJ.

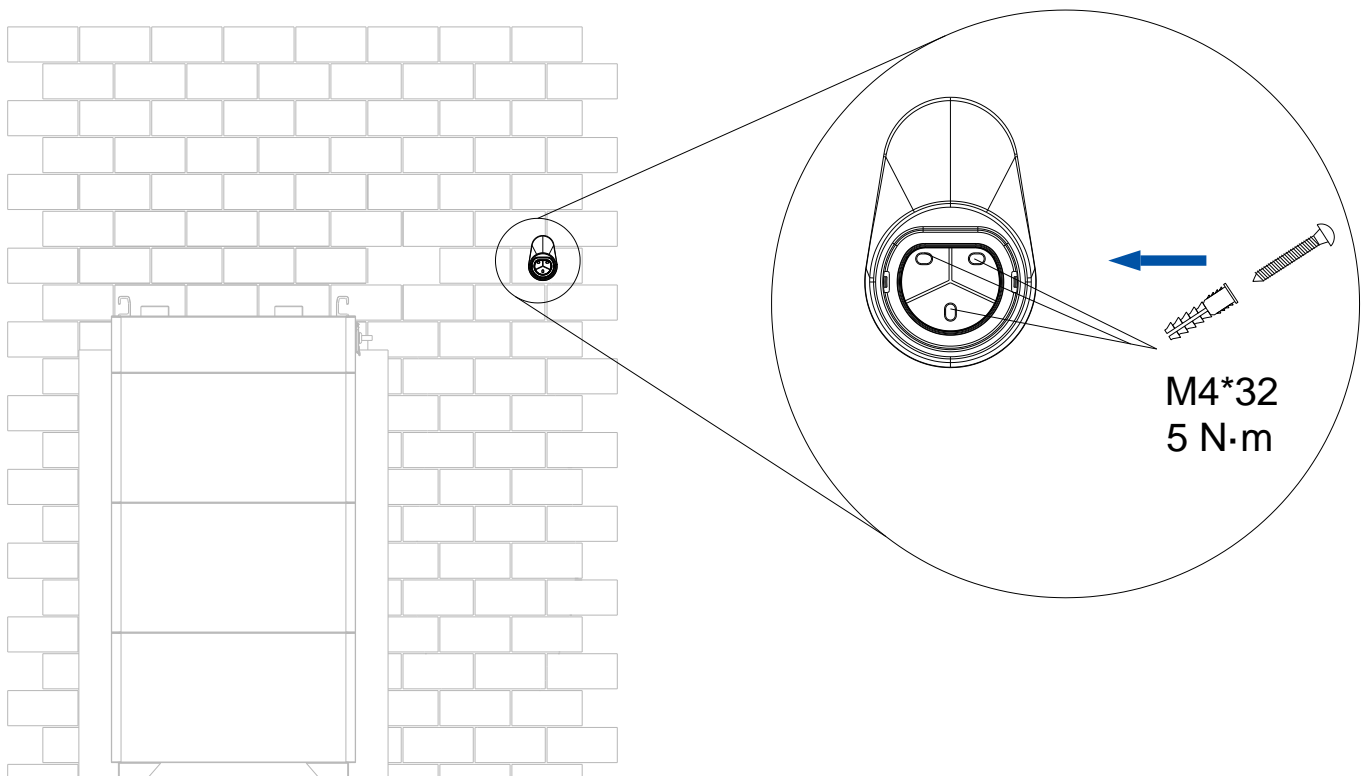

5.4. Install the inverter (HS3-xk-T2-(W, G)-(B, P) or HS3-xK-T2-(W, G)-(B, P)-(BE, IE))

1. (Optional) If you have installed a charger, loosen the screws on the inverter, and remove the port cover, as shown below:

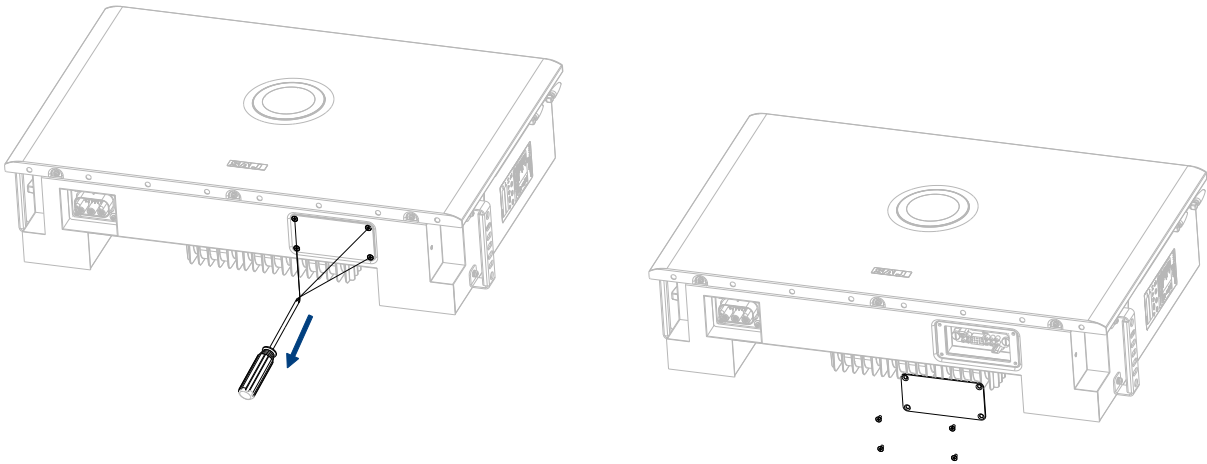

2. Place the inverter onto the battery or charger (if available). Push it downwards. Install screws on both lower sides of the inverter to secure the inverter to the beneath device (battery or charger; here takes a charger as an example).

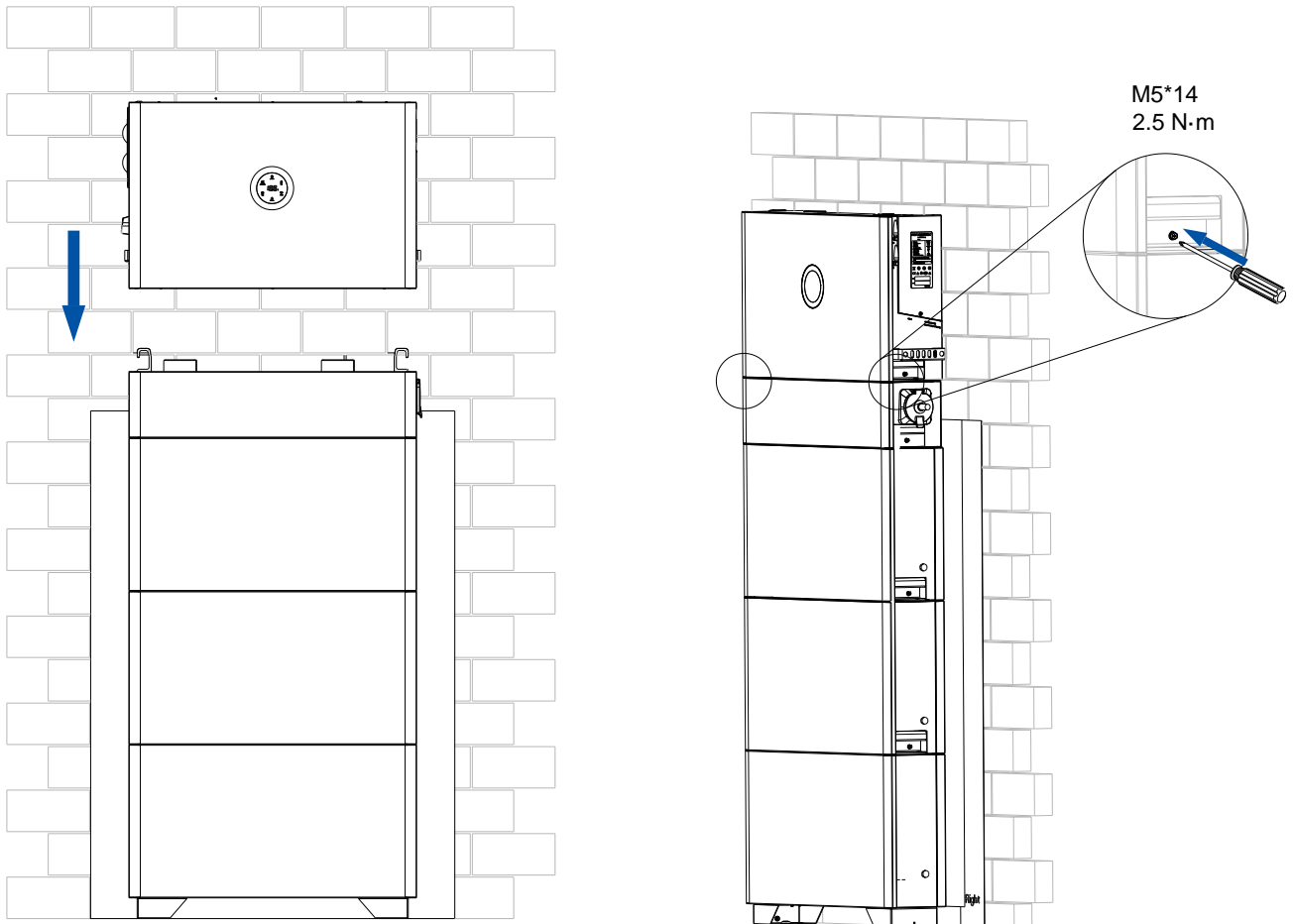

Australia only: As shown below, install the metal grounding plate and secure it by installing two M4*12 screws.

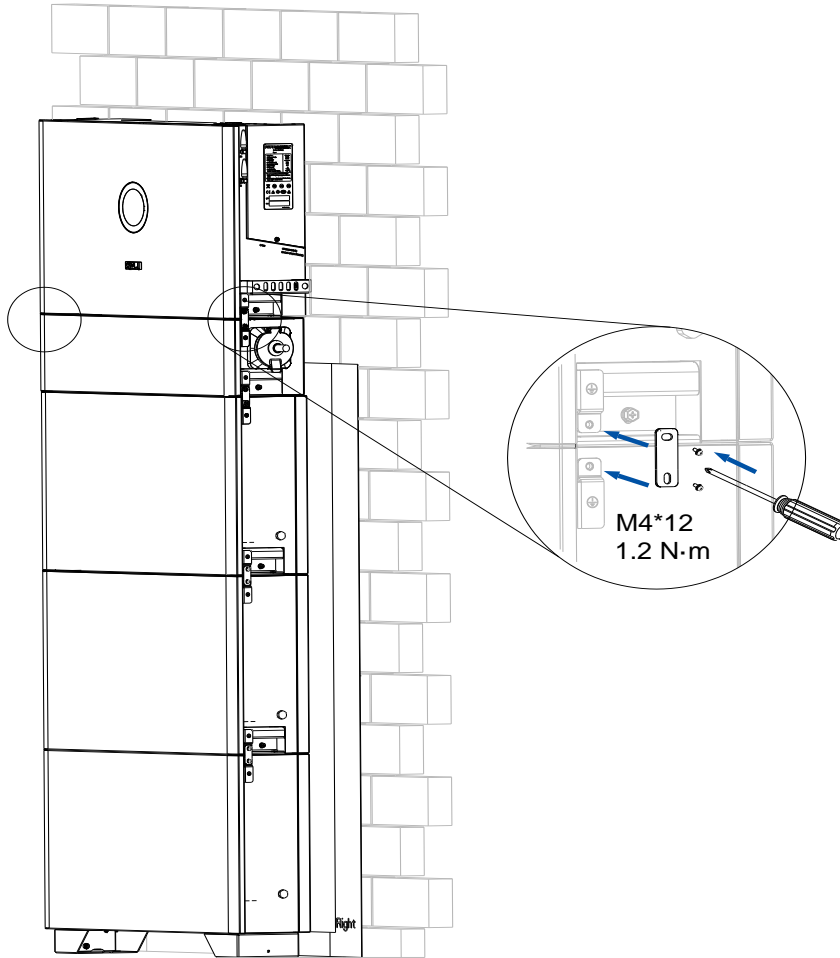

Completion View

Example of 3 batteries:

Inverter + charger + batteries

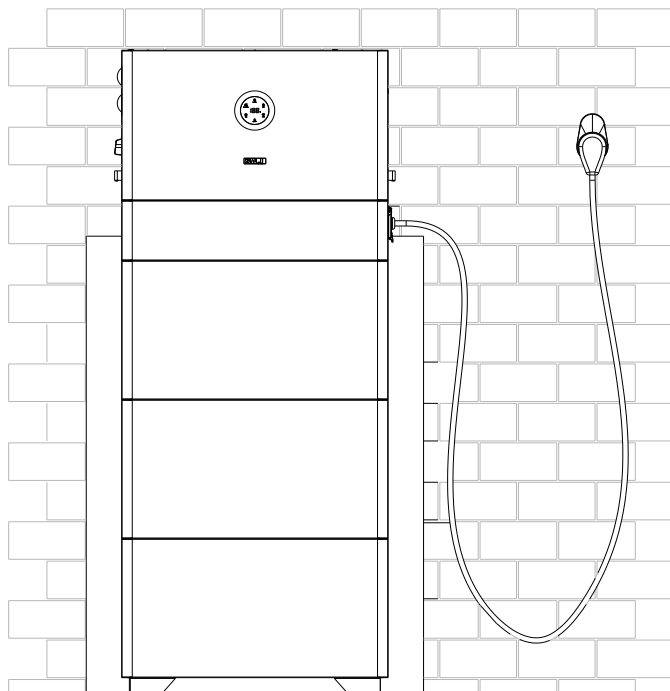

Inverter + batteries

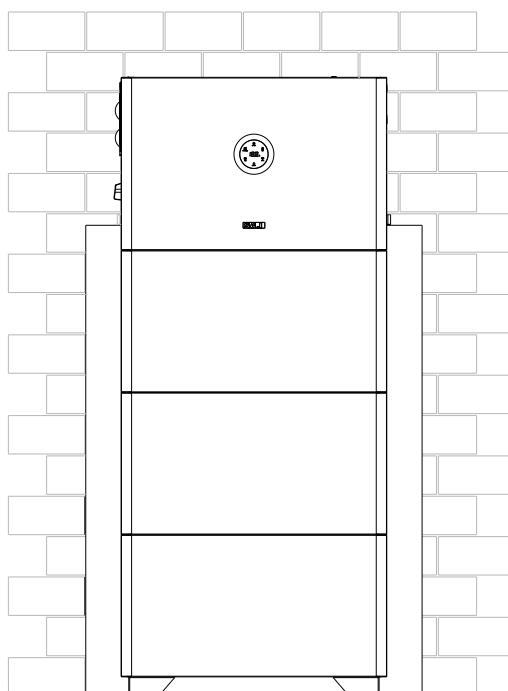

□ 6. Install type B battery pack: wall-mounting manner

6.1. Install the wall-mounting bracket (BT3-TV)

1. Place the mounting bracket onto the wall. Mark six holes. Remove the bracket.

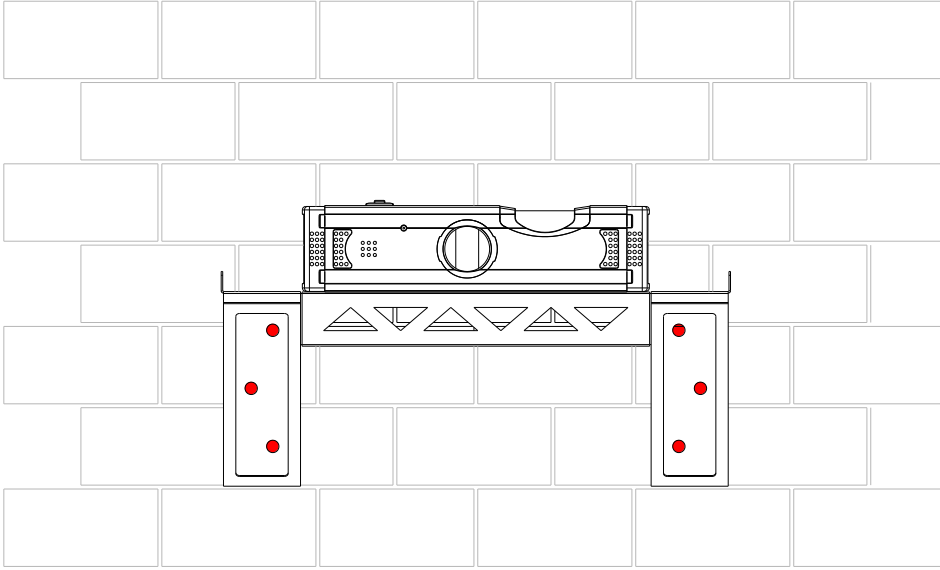

2. Drill six holes according to the marked positions on the wall.

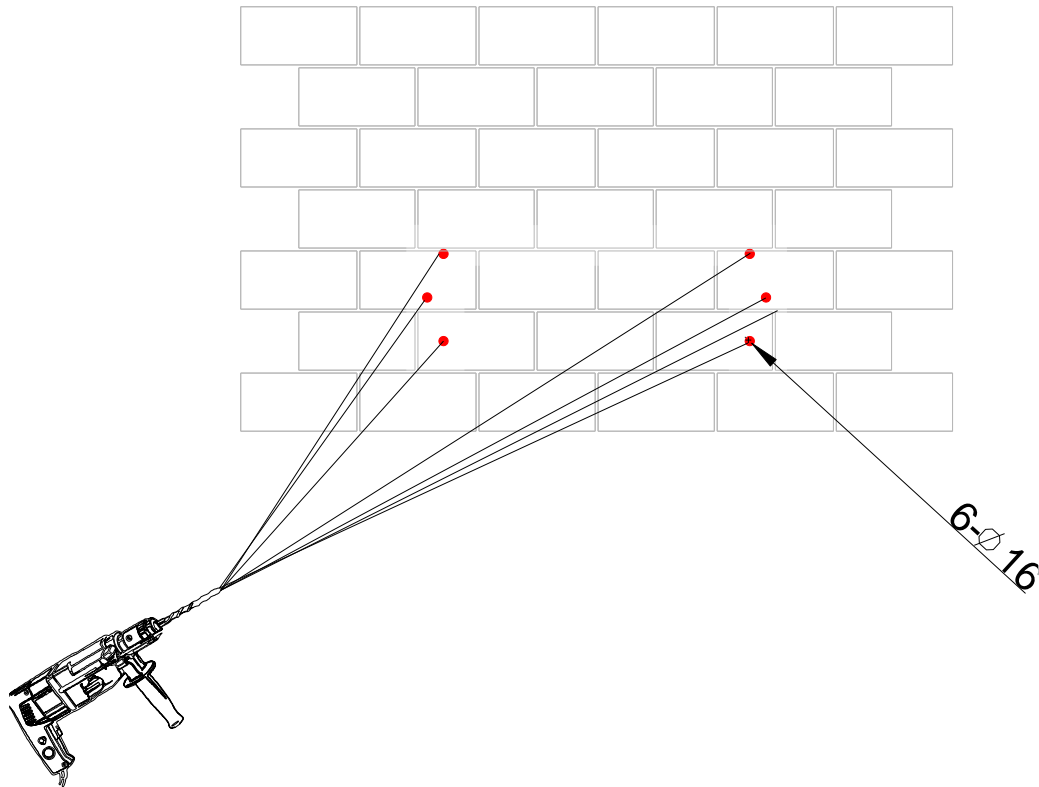

3. Install the mounting bracket on to the wall.

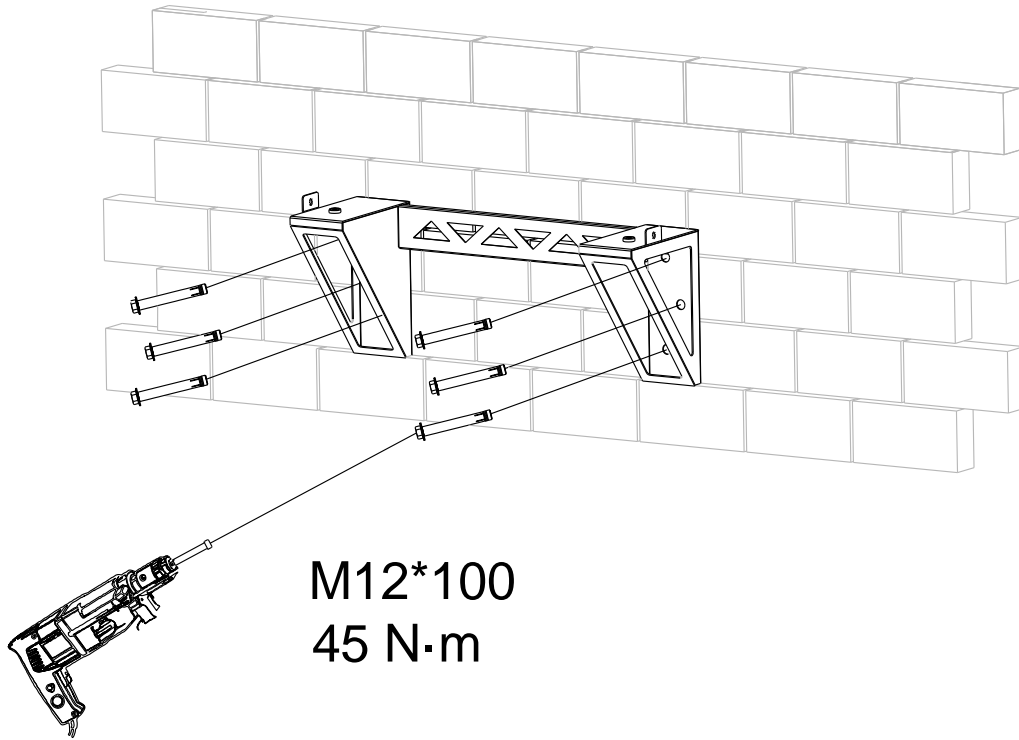

6.2. Install the base battery (BU3-5.0-(TV1, TV2)-BASE or BU3-5.0-(TV1, TV2)-PRO-BASE)

1. Get the cardboard from the base battery package. Place the cardboard on to the wall. Place the cardboard onto the wall by aligning the vertical lines with the bracket edges.

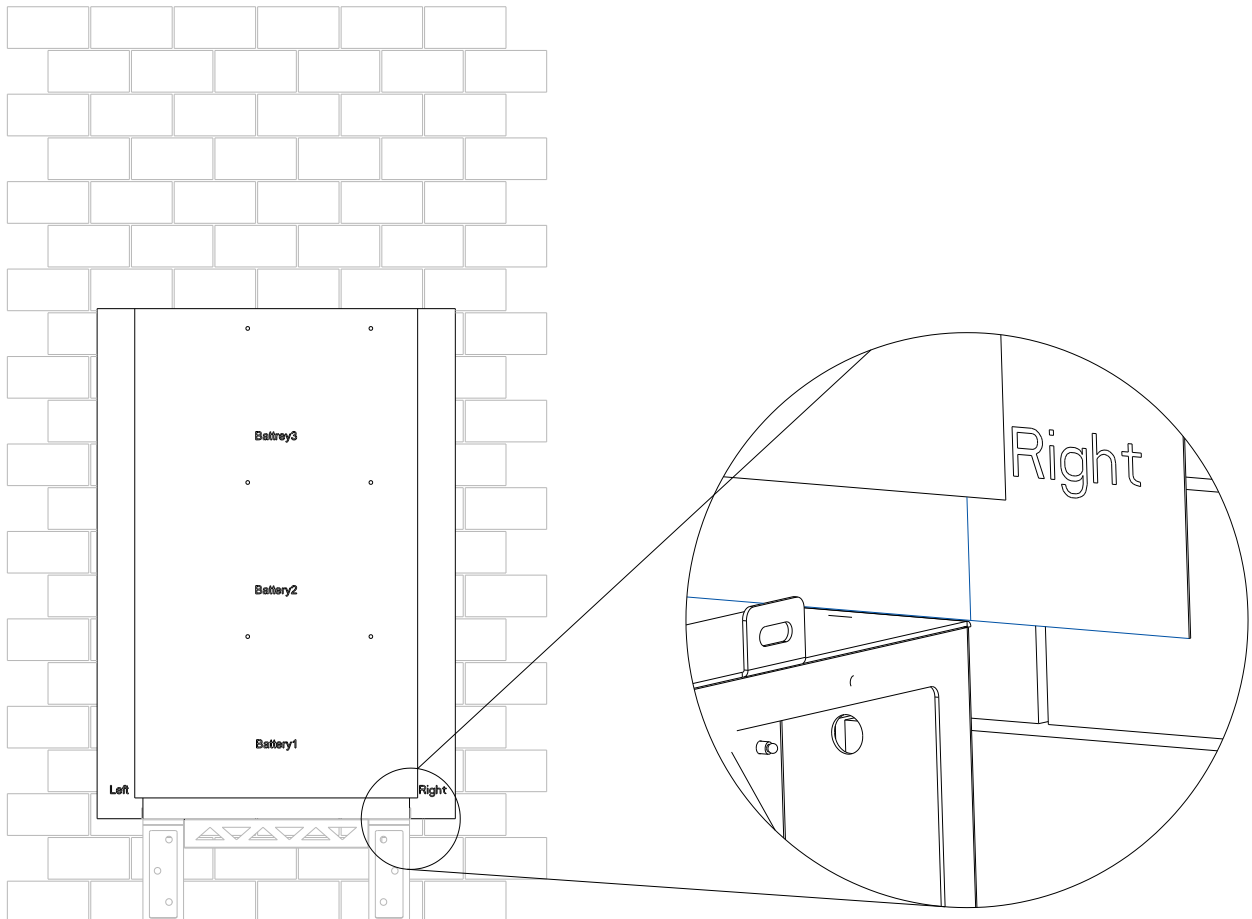

- Drill six holes (8mm in diameter and 55mm in depth) on the marked positions on the cardboard. Install the provided expansion bolts into the drilled holes.

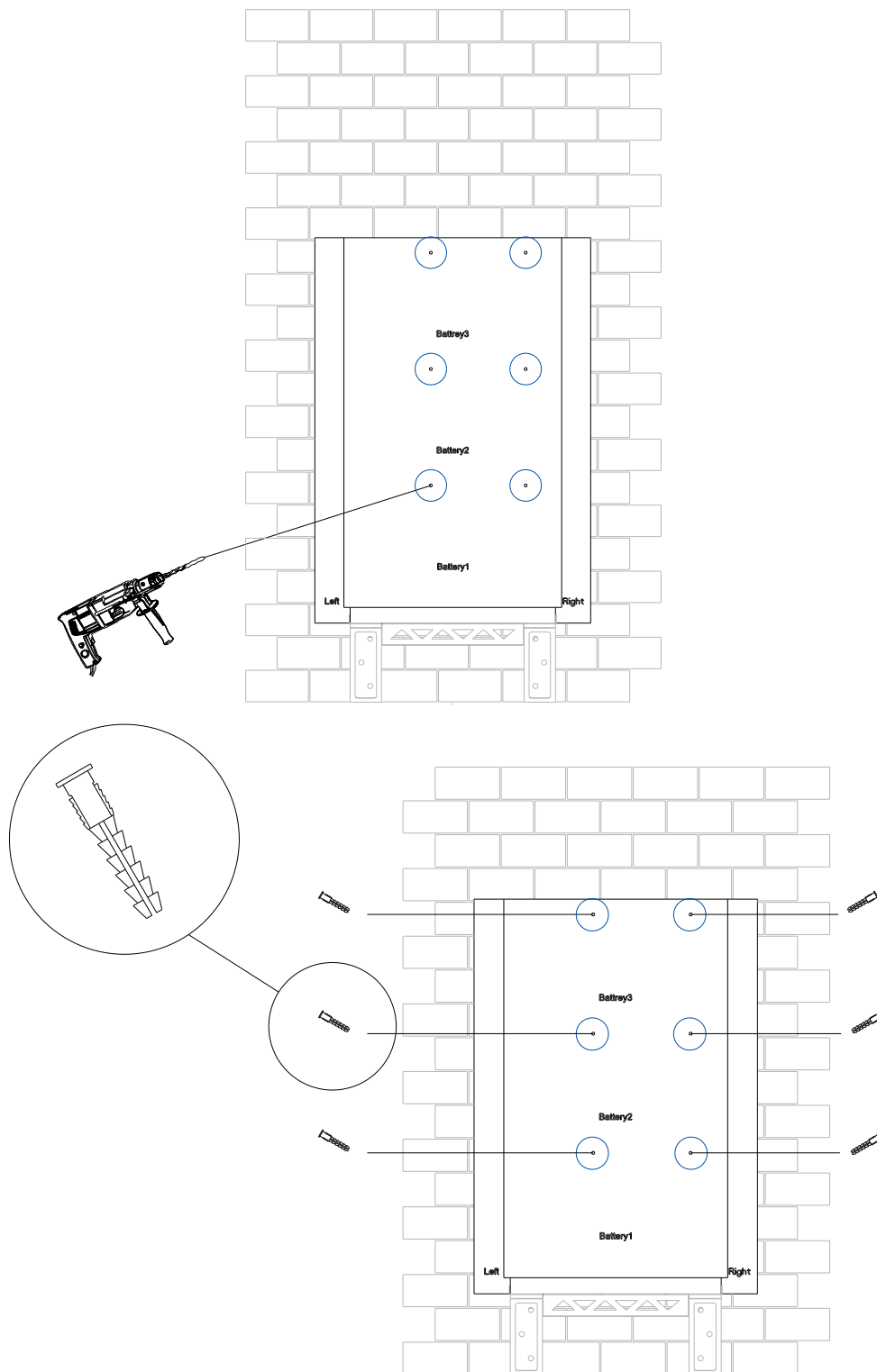

- Use two M5*14 screws to install two locking brackets to the mounting ears on the top of the battery pack. Place the base battery onto the floor. Make sure that:
 - The battery feet are aligned with the vertical black line on the cardboard.
 - It is recommended to use a gradienter to make sure that the battery is placed horizontally.
 - The space between the battery back and the wall surface is 40–50 mm.

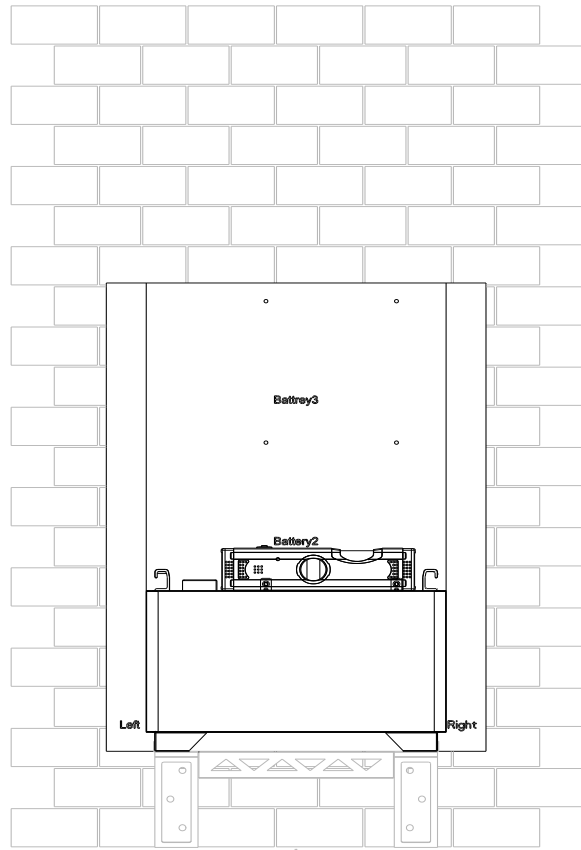
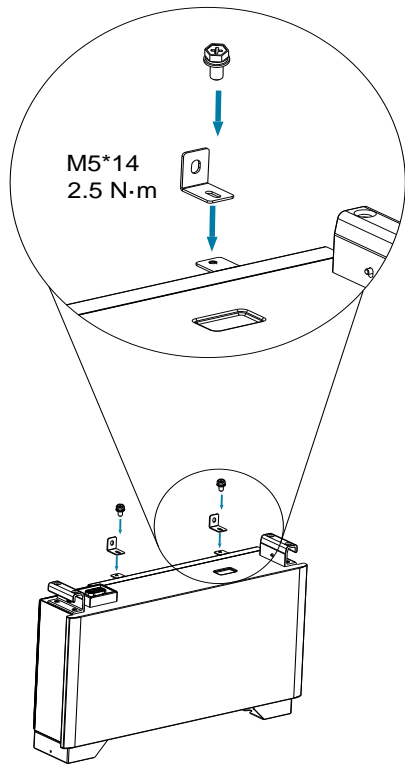

- On the top of the battery pack, align the locking brackets to the drilled holes and install M6*50 screws to secure the locking brackets to the wall. Secure battery to the wall-mounting bracket by tightening two M6*14 screws.

Note: If the battery is installed outdoors, it is suggested to remove the cardboard which is not waterproof.

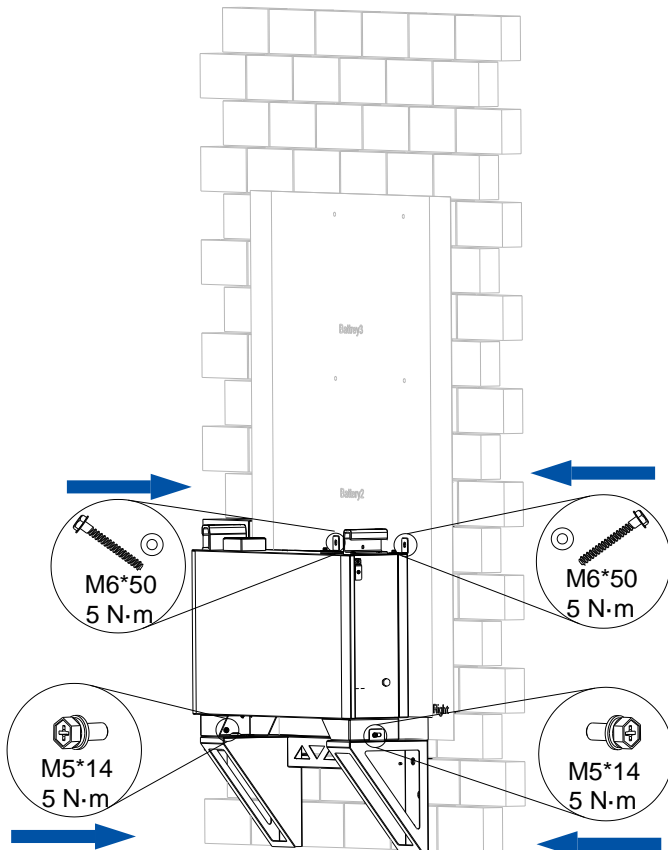

6.3. Install other required devices

For details, refer to the same procedure (steps 5.2 to 5.4) in the ground mounting manner.

- (Optional) Battery without a base (BU3-5.0-(TV1, TV2) or BU3-5.0-(TV1, TV2)-PRO): Step 5.2
- (Optional) Charger (CU2-11K-T-I): Step 5.3
- Inverter (HS3-xk-T2-W-B, HS3-xk-T2-W-P, HS3-xk-T2-G-B, or HS3-xk-T2-G-P): Step 5.4
- (Optional) Battery combiner box (BC3-TV): Step 7

7. (Optional) Install a battery combiner box (BC3-TV)

One inverter supports up to eight batteries; however, for safety reason, a maximum of three batteries can be installed vertically in one stack.

Therefore, extra batteries must be installed in other stack(s) and the extra battery stack must be installed with a battery combiner box (BC3-TV).

Due to the cable length limitations, the distance between each battery stack is 0.5 meter.

It is recommended that the batteries be assembled in different stacks as follows:

| Quantity of batteries supported by one inverter | Quantity of battery stacks | Quantity of batteries in each stack |
|---|----------------------------|-------------------------------------|
| 1, 2, or 3 batteries | 1 stack | 1, 2, or 3 |
| 4 batteries | 2 stacks | 2, 2 |
| 5 batteries | 2 stacks | 3, 2 |
| 6 batteries | 2 stacks | 3, 3 |
| 7 batteries | 3 stacks | 3, 2, 2 |
| 8 batteries | 3 stacks | 3, 3, 2 |

1. Place the combiner box onto the battery. Push it downwards.

On a type A battery pack

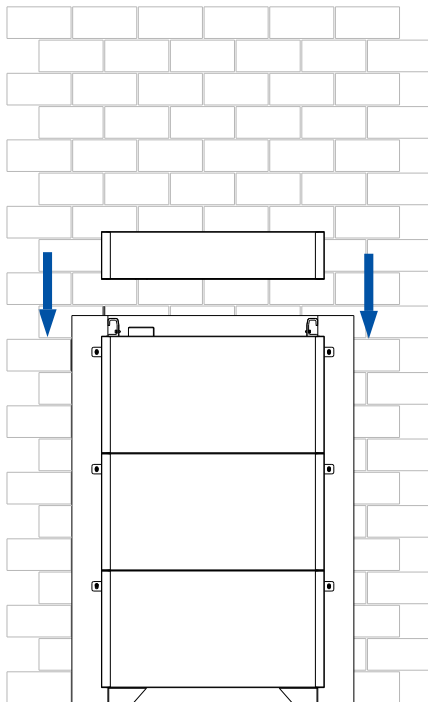

On a type B battery pack

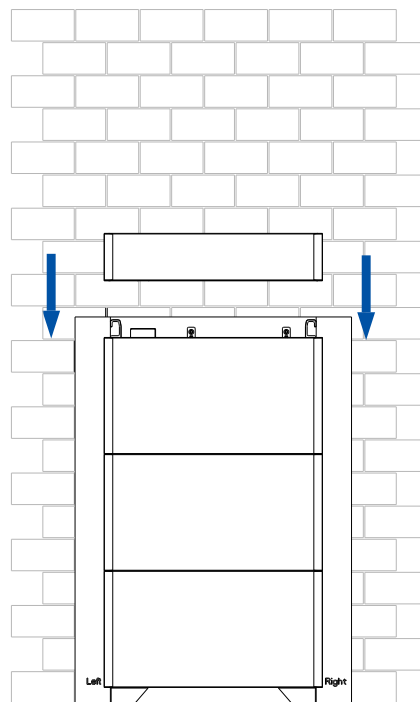

2. Depending on the battery type, perform as follows:

- Type A battery pack: Install screws on both lower sides of the junction box to secure the junction box to the beneath battery.

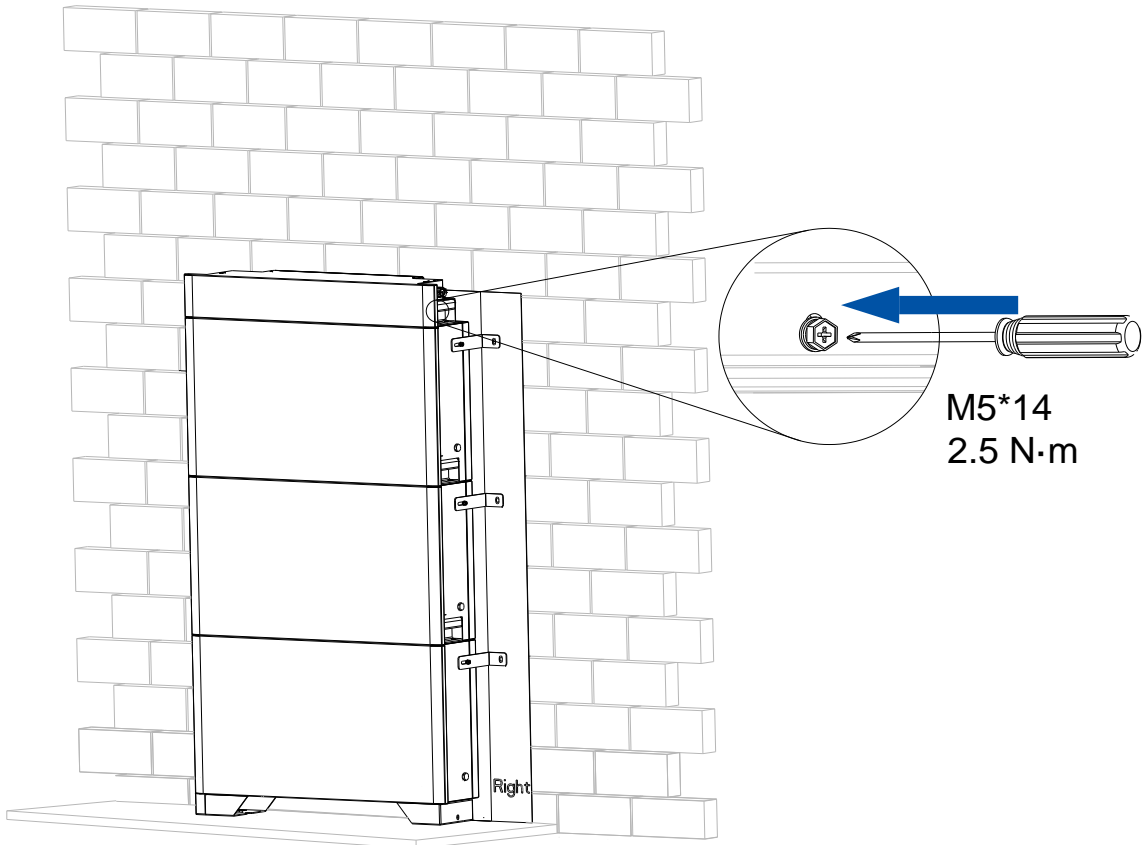

- Type B battery pack: Install screws on both lower sides of the junction box to secure the junction box to the beneath battery.

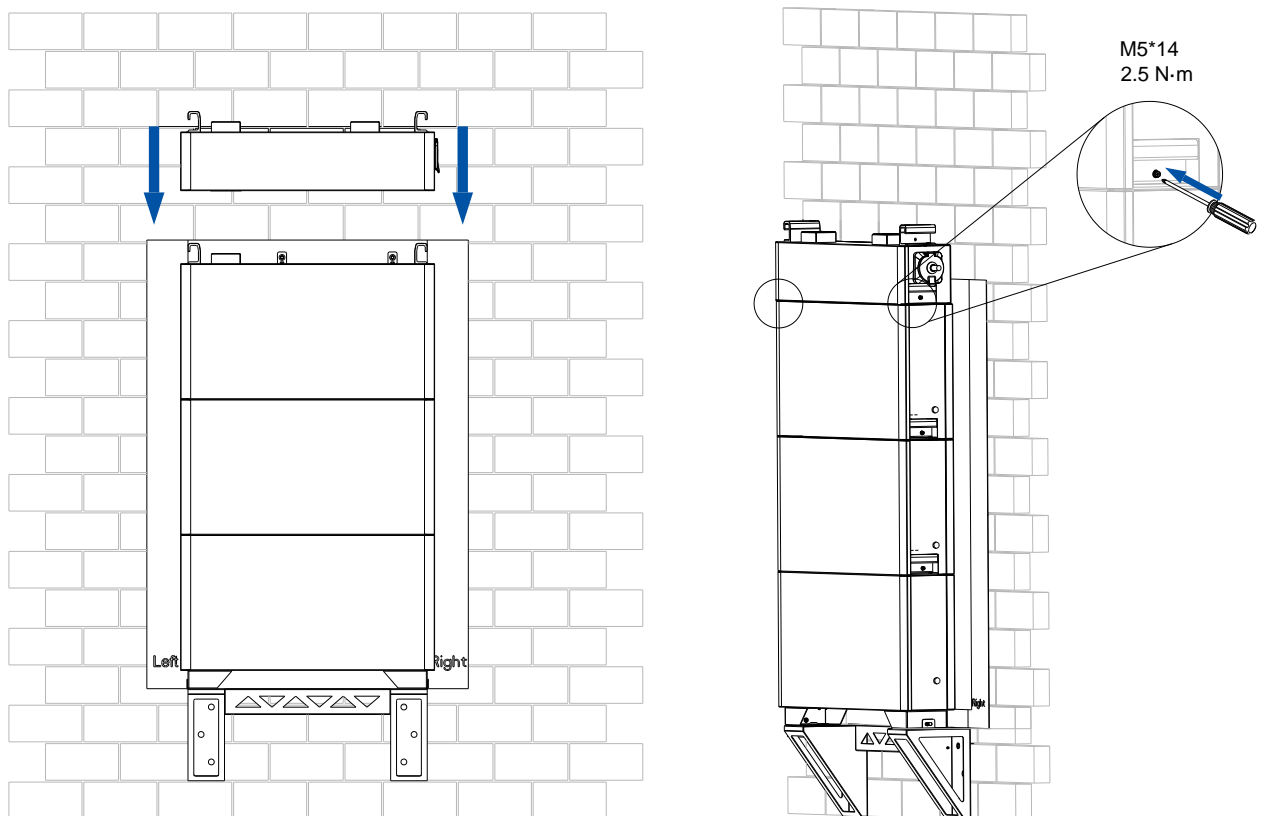

Australia only: As shown below, install the metal grounding plate and secure it by installing two M4*12 screws.

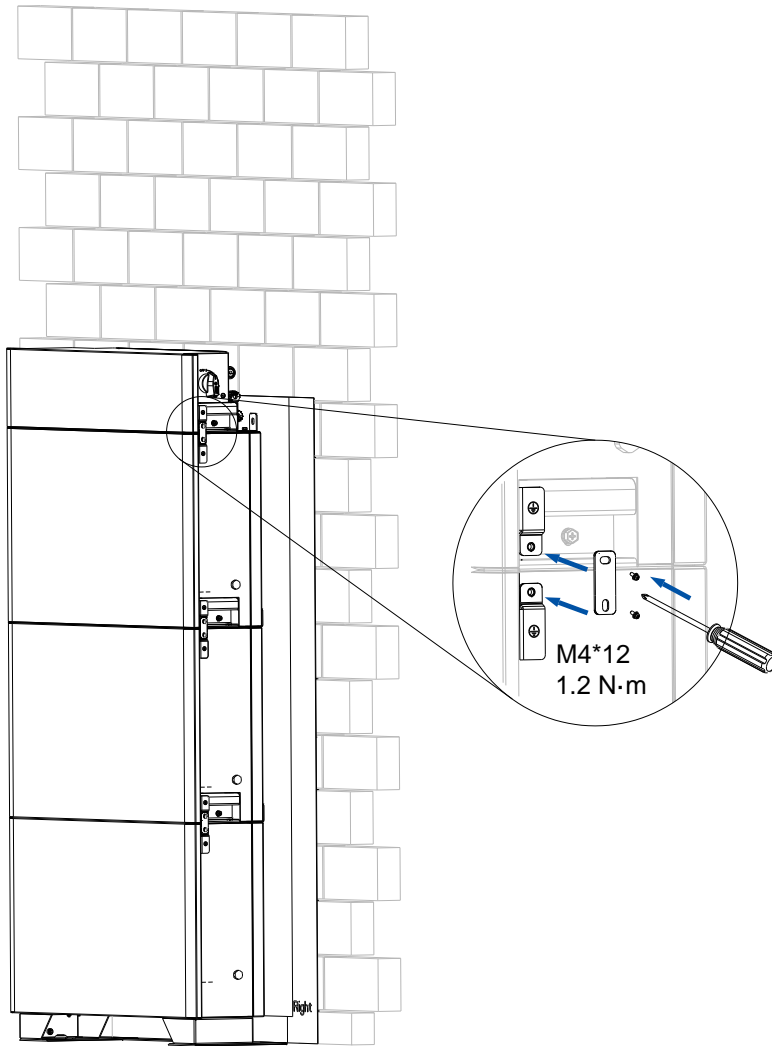

Completion View

Example of 8 batteries:

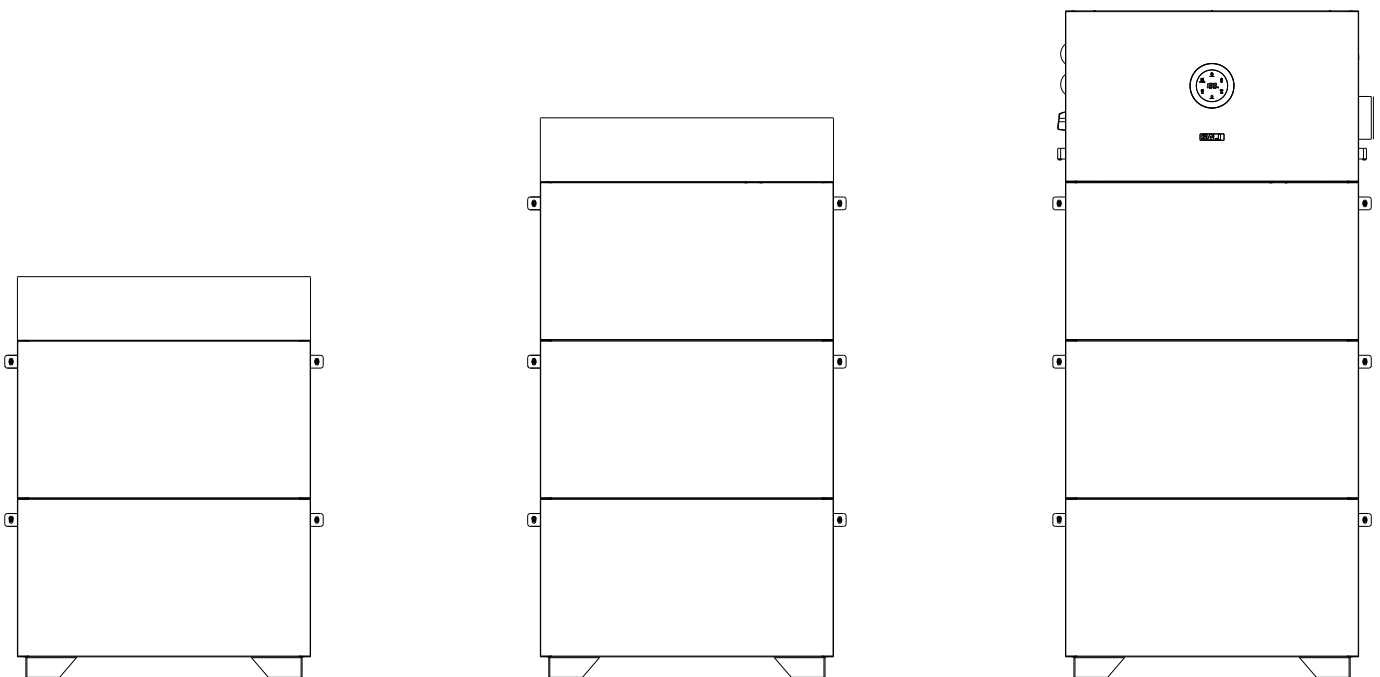

□ 8. Assemble the AC-side connection

1. Open the AC-side cover.

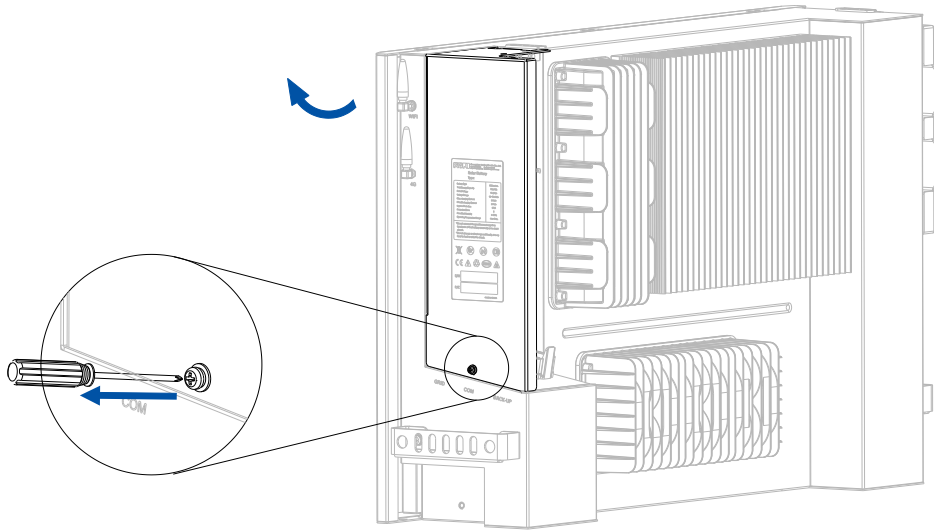

2. Connect the grounding cable, by taking AC-side grounding as an example.

The cable needs to be prepared by the user. It is recommended that a 6-mm² conductor cross-sectional area of cable be used.

- a. Assemble the cable and OT/DT terminal.

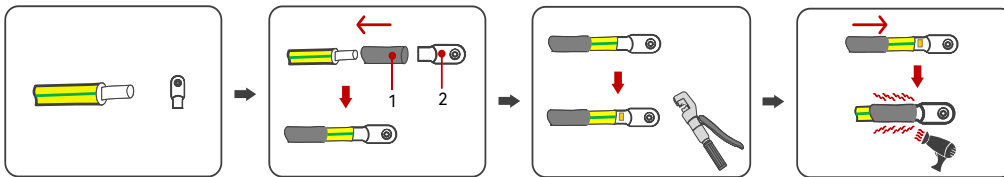

| | | | |
|---|------------------|---|----------------|
| 1 | Heat shrink tube | 2 | OT/DT terminal |
|---|------------------|---|----------------|

- b. Remove the M4*10 screw from the grounding port. Connect and secure the grounding cable, as shown below:

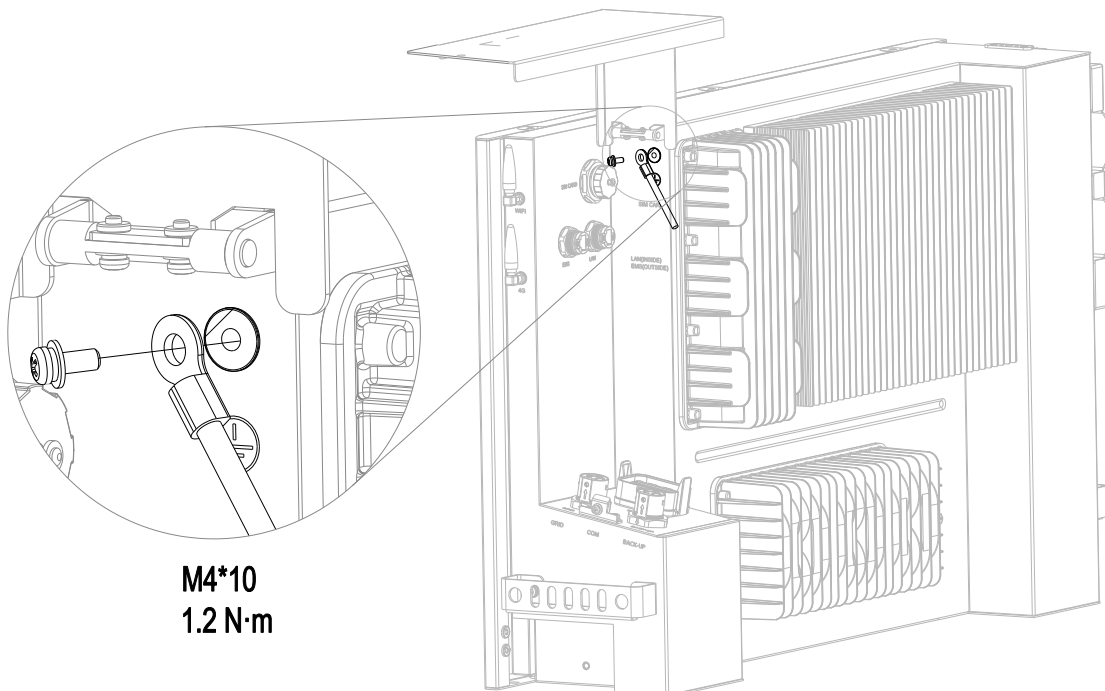

3. (4G model only) Install the SIM card: Loosen the cover of the SIM card slot. Then, insert the SIM card into the slot.

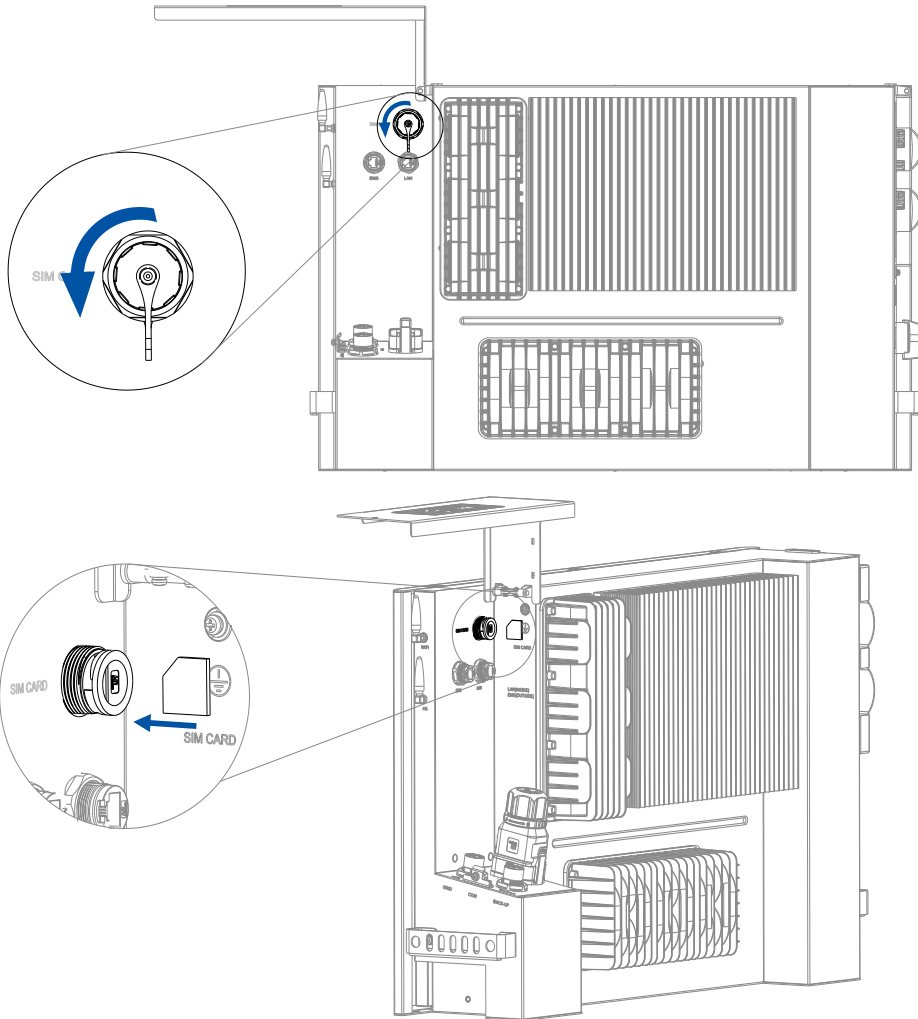

4. (W model only) Install the LAN cable, if you choose to use the Ethernet connection manner.
 - a. Remove the RJ45 cable fastener from the LAN port.
 - b. Use a standard RJ45 cable. Insert the cable through the cable fastener as shown below. Assemble the cable fastener.
 - c. Connect the LAN cable from the LAN port on the inverter to the router.

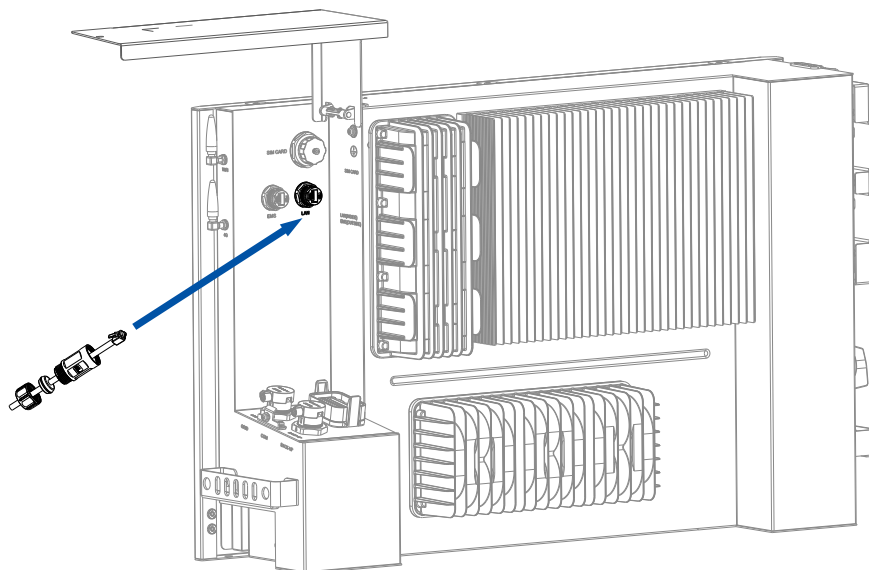

5. Install the EMS cable.
 - a. Connect the cable from the EMS port on the inverter to the LAN port on SAJ eManager (EMS). Remove the RJ45 cable fastener from the EMS port.
 - b. Use a standard RJ45 cable. Insert the cable through the cable fastener as shown below. Assemble the cable fastener.
 - c. Connect the cable from the EMS port on the inverter to the LAN port on SAJ eManager (EMS).

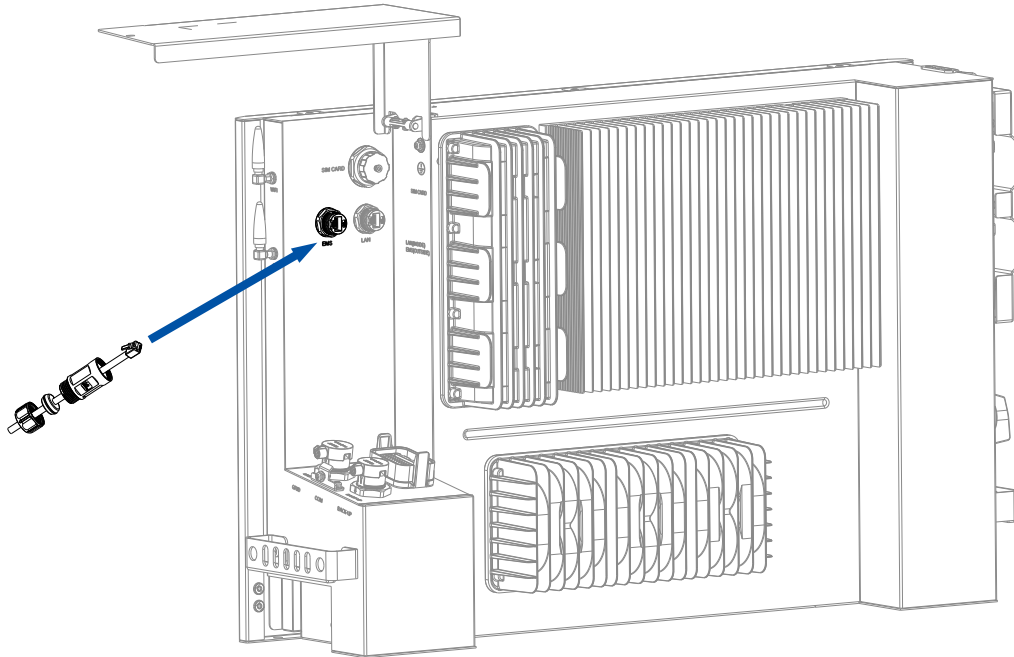

6. Install a circuit breaker.
For safety operation and regulation compliance, install a 63 A or higher air circuit breaker between the grid and the inverter.
7. (Optional) Install an RCD.
If the external RCD must be installed according to the local regulations, either type A or type B RCD can be installed with the action current 300 mA or higher.
8. Connect the grid and backup loads.

Recommended cable specification:

| Conductor cross-sectional area of cables | | Conductor material |
|--|-----------------------------|--------------------|
| Range | Recommended value | |
| 4–6 mm ² or 12–10 AWG | 6 mm ² or 10 AWG | Copper |

Note the required cable diameter of different rubber plugs.

| Rubber plug | Hole diameter |
|---------------------------------------|---------------|
| One-hole plug (in the connector) | 14–17.5 mm |
| Five-hole plug (in the accessory bag) | 4.0–5.5 mm |

- a. Strip the insulation off (13-mm length) the cables.
- b. Insert the cables through the dustproof cover, nut, and connector body of the connector and secure the cables to the terminal block with a spanner.

Note: The black connector is for grid connection. The blue connector is for backup load connection.

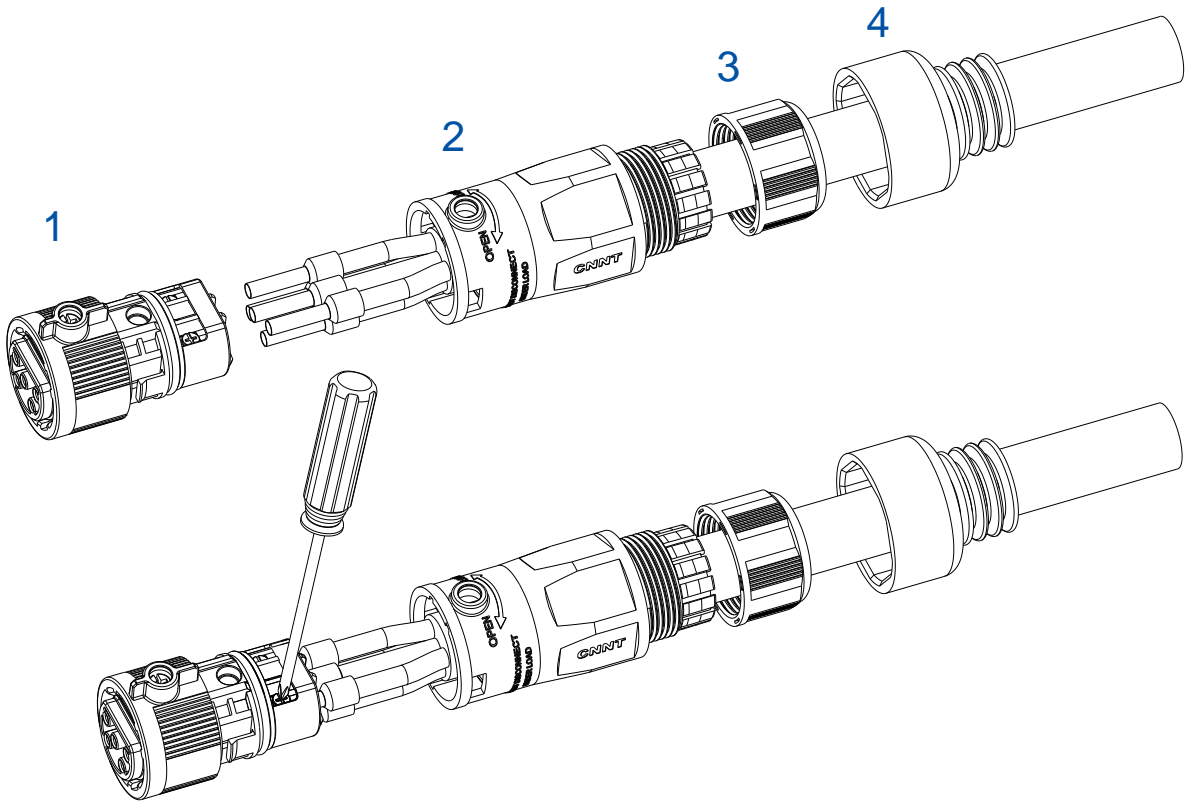

- c. Remove the dustproof covers from the GRID and BACK UP ports.
Use a screwdriver to loosen the screw of the dustproof cover.
Pull the covers upwards.

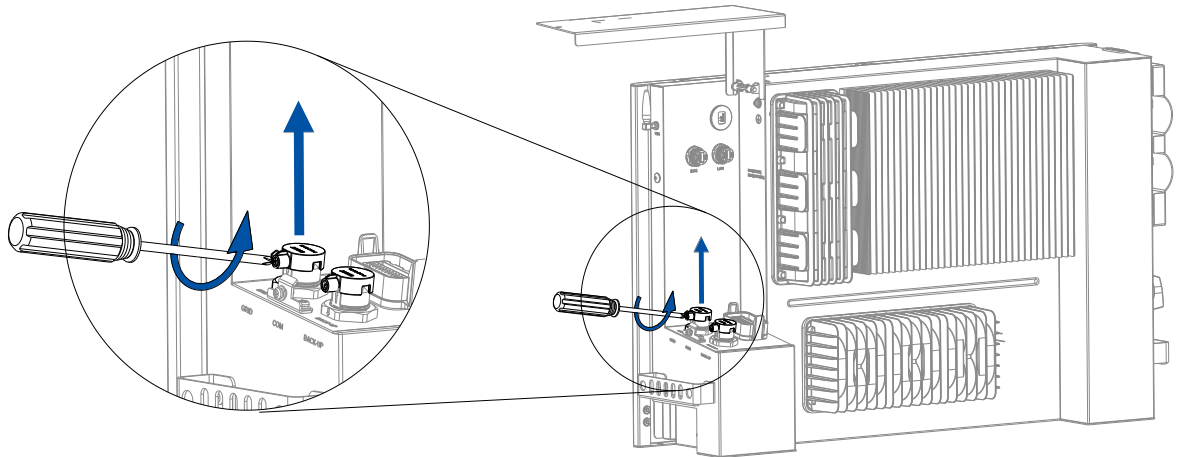

d. Connect the cables to the GRID and BACKUP ports on the inverter.

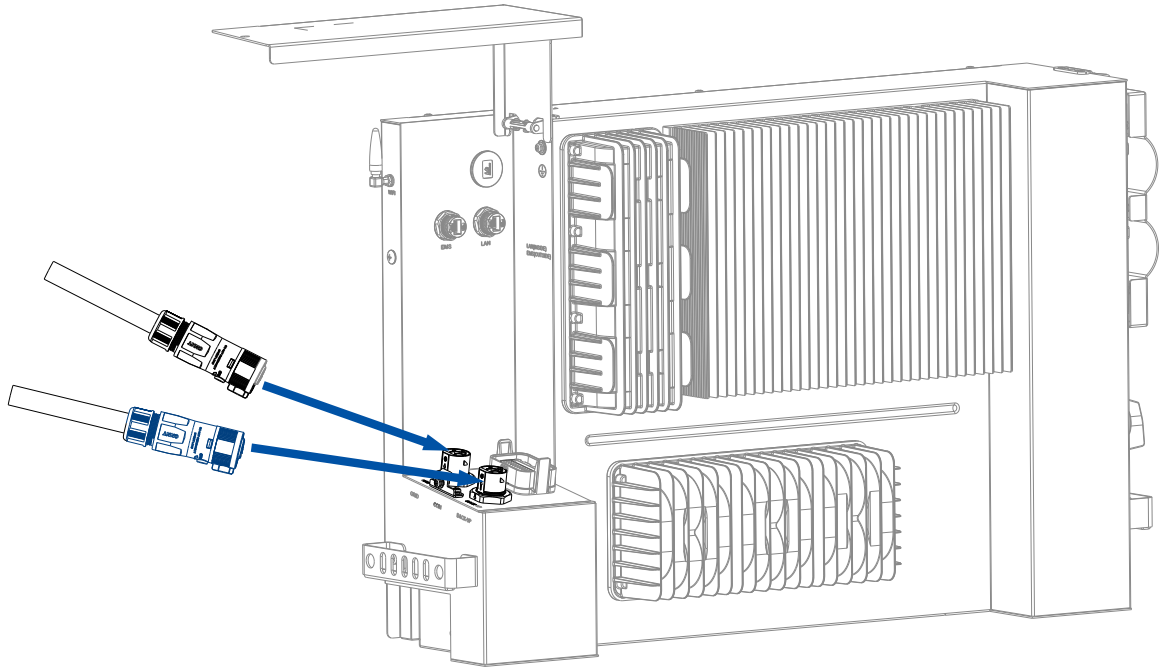

e. Tighten the screws of the GRID and BACKUP ports on the inverter.

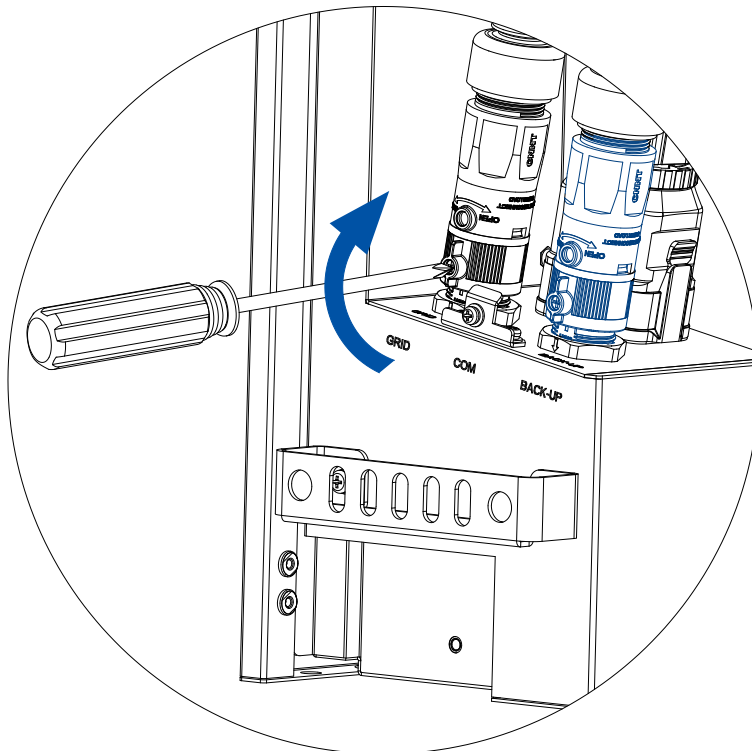

9. Assemble the communication connection.

a. Disassemble the communication cable connector.

- ① Press the tabs on two sides of the connector by one hand and press the front ends of the terminal by another hand. Pull the connection terminal block outwards.
- ② Rotate the nut anti-clockwise and remove it from the connector body.
- ③ Remove the rubber plugs out of the seals.

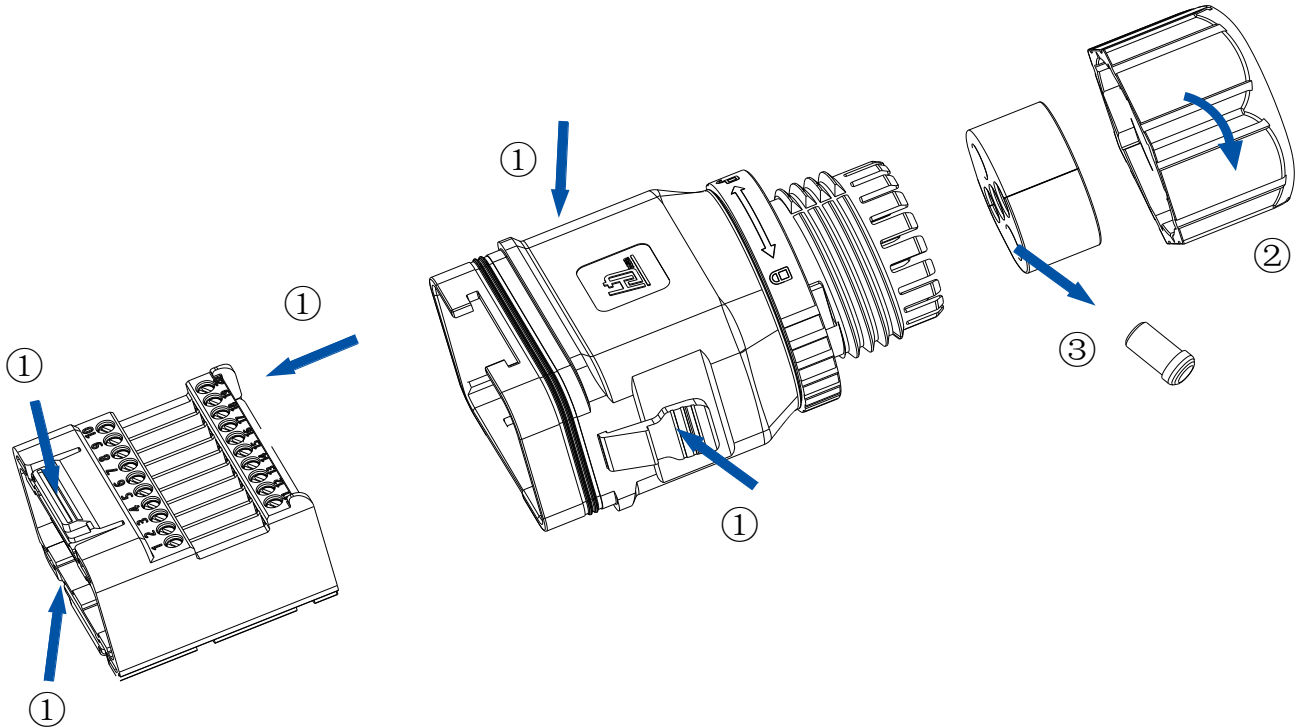

b. Connect all communication cables to the communication cable connector.

① Prepare cables.

- Meter communication: Use the provided communication cable kit. It contains a communication cable with an RJ45 port and two assembled terminals and cable fastener parts.

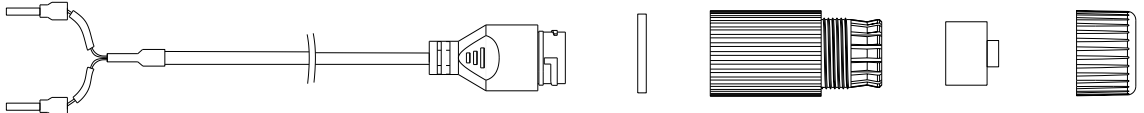

- Other terminal connection: Per you needs, prepare cables. Strip the insulation around 7.5 mm on cable ends and if needed, use provided insulated crimp terminals on the cable ends.

Suggested cable specifications:

- DO: 0.5-0.75 mm²
- Others: 0.2-0.5 mm²

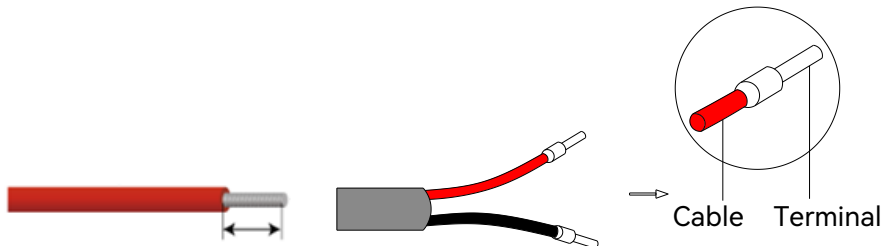

- ② Insert all communication cables through the nut, seals, and body of the connector.

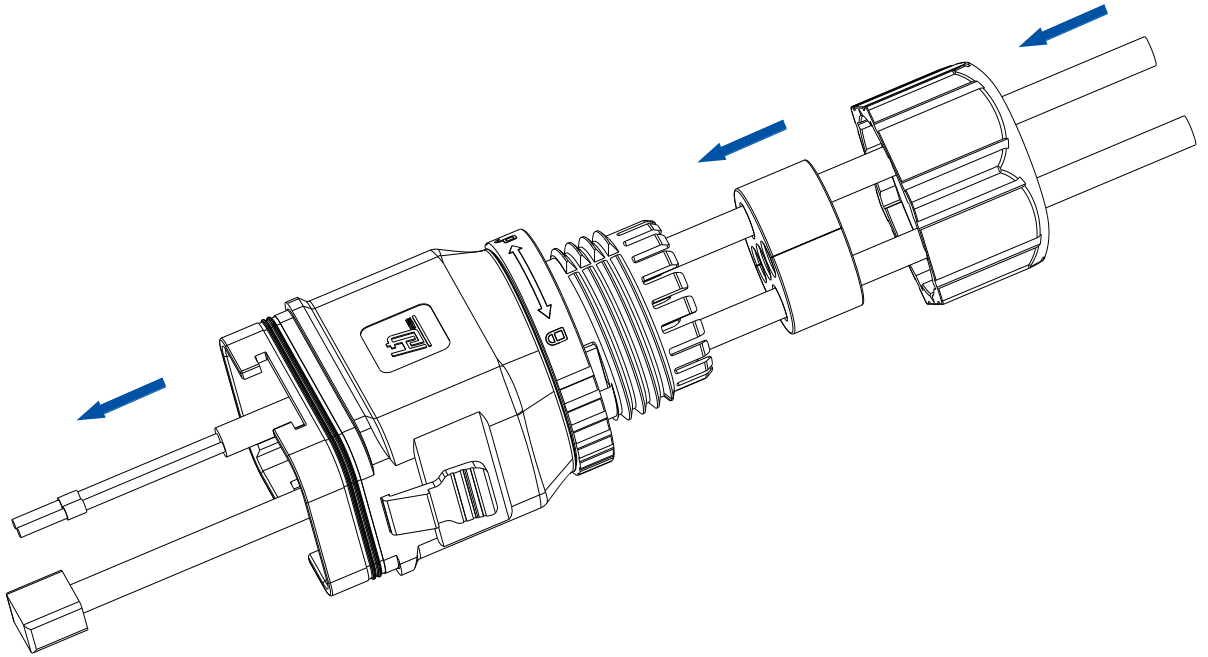

- ③ Locate the ports and terminals on the connection terminal block according to their silkscreens.

| Name | Number | Pin definition | Description |
|------------------|----------------------------------|-------------------------------------|--------------------------------------|
| PORT (RJ45 port) | / | 1: CAN-H (with a 120 Ω resistor) | For parallelling connection scenario |
| | | 2: CAN-L | |
| | | 3: GND_W | |
| | | 4: SYN | |
| | | 5: GND_W | |
| | | 6: HOST | |
| | | 7: GND_W | |
| | | 8: TRF | |
| DRMs (RJ45 port) | / | 1: DRM1/5 | For RCR |
| | | 2: DRM2/6 | For RCR |
| | | 3: DRM3/7 | For RCR |
| | | 4: DRM4/8 | For RCR |
| | | 5: REF D/0 | / |
| | | 6: COM D/0 | / |
| | | 7: NC | / |
| | | 8: NC | / |
| Terminals | 4 | DO1+ | Dry output 1 |
| | 5 | DO1- | Dry output 1 |
| | 6 | DO2+ | Dry output 2 |
| | 7 | DO2- | Dry output 2 |
| | 11 | RS485-A (with a 120 Ω resistor) | For external RS485 communication |
| | 12 | RS485-B | |
| | 13 | MET-A (with a 120 Ω resistor) | For meter communication |
| | 14 | MET-B | |
| | 15 | DI1+ | Dry input 1 |
| | 16 | DI1- | Dry input 1 |
| | 17 | DI2+ | Dry input 2 |
| | 18 | DI2- | Dry input 2 |
| 19 | CAN_H (with a 120 Ω resistor) | For external CAN communication | |
| 20 | CAN_L | | |

c. Connect and secure the cables to the connection terminal block. Then, assemble the communication cable connector.

- ① Connect cables to corresponding terminals and RJ45 ports based on your needs.
- ② Use a screwdriver to secure the cables connected to the terminals.

Note: If any terminal that has been equipped with a 120 Ω resistor, such as METER-A, needs to be connected by a cable with the length longer than 20 meters, switch the resistor to ON status.

- ③ Insert the connection terminal block back to the connector body until you hear a click sound.
- ④ Insert the seals and nut back to the connector body.
- ⑤ Rotate the nut clockwise until it is secured to the connector body.

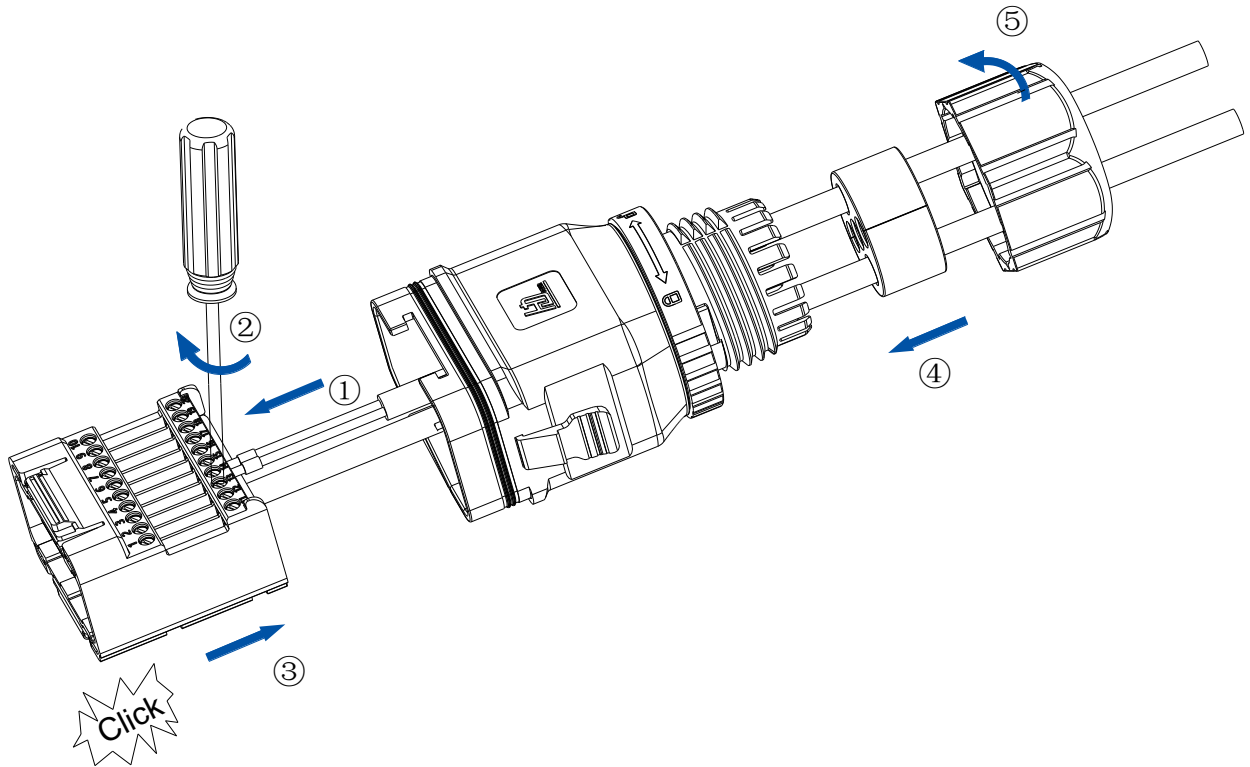

d. Connect the assembled communication terminal connector to the COMM port on the inverter.

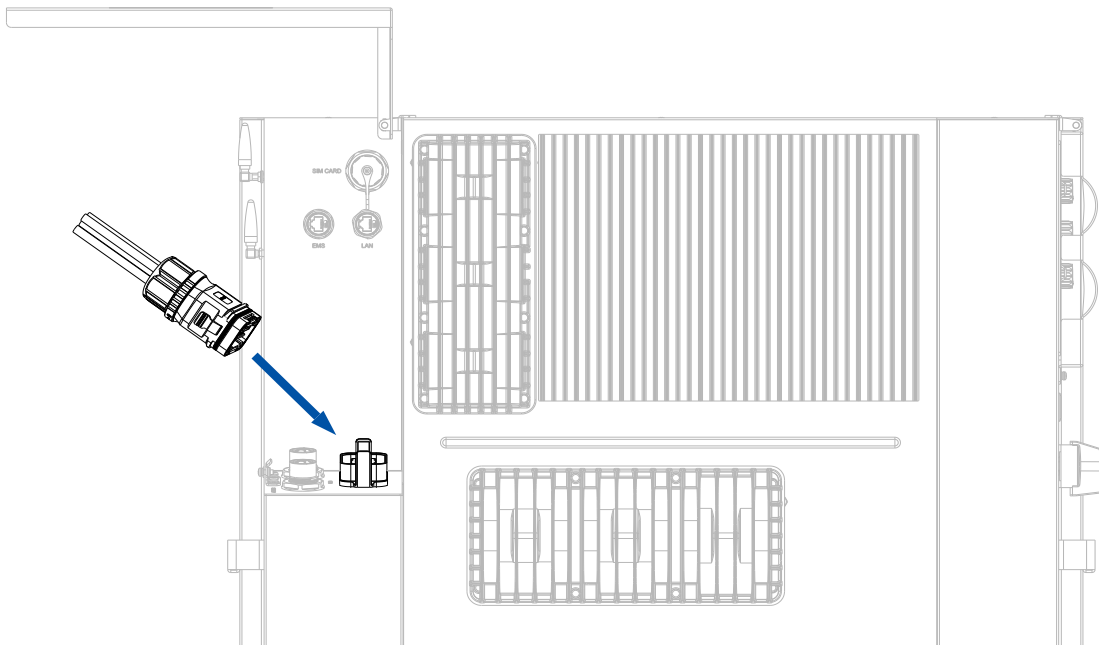

e. Connect the other end of the cables to external devices, such as the meter.

Meter connection:

- ① Take the communication cable (A) and smart meter out of the meter kit. For details, refer to the inverter package in step 2 "Check the product packages".
- ② Connect the RJ45 connector of the cable to the RJ45 port of the meter communication cable (B).
- ③ Connect the two crimped cable ends of the cable to ports 24 and 25 on the meter.

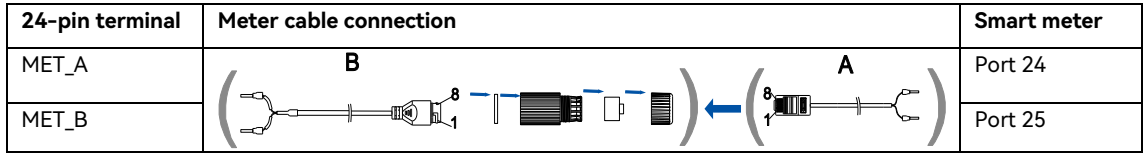

| Callout | Description | RJ45 pin definition |
|----------|--|---|
| A | Communication cable with an RJ45 connector | <ul style="list-style-type: none"> ● Pin 1: A1 ● Pin 2: B1 ● Pins 3 to 8: NC |
| B | Communication cable kit | <ul style="list-style-type: none"> ● Pin 1: For MET-A ● Pin 2: For MET-B ● Pins 3 to 8: NC |

10. Close the AC-side cover.

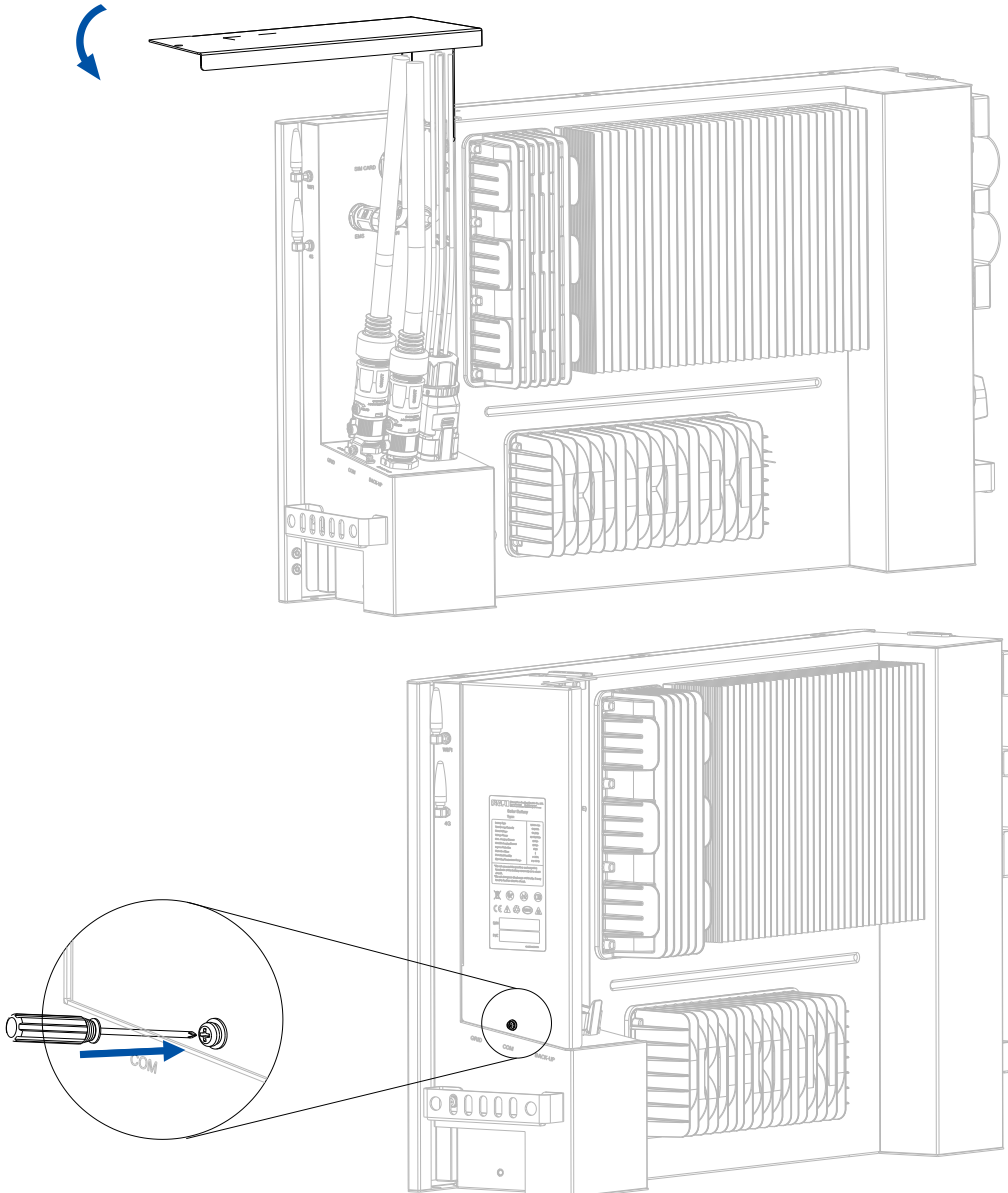

9. Assemble the DC-side connection

1. Open the DC-side cover.

Loosen the screw that locks the cover. Then, lift the cover upwards.

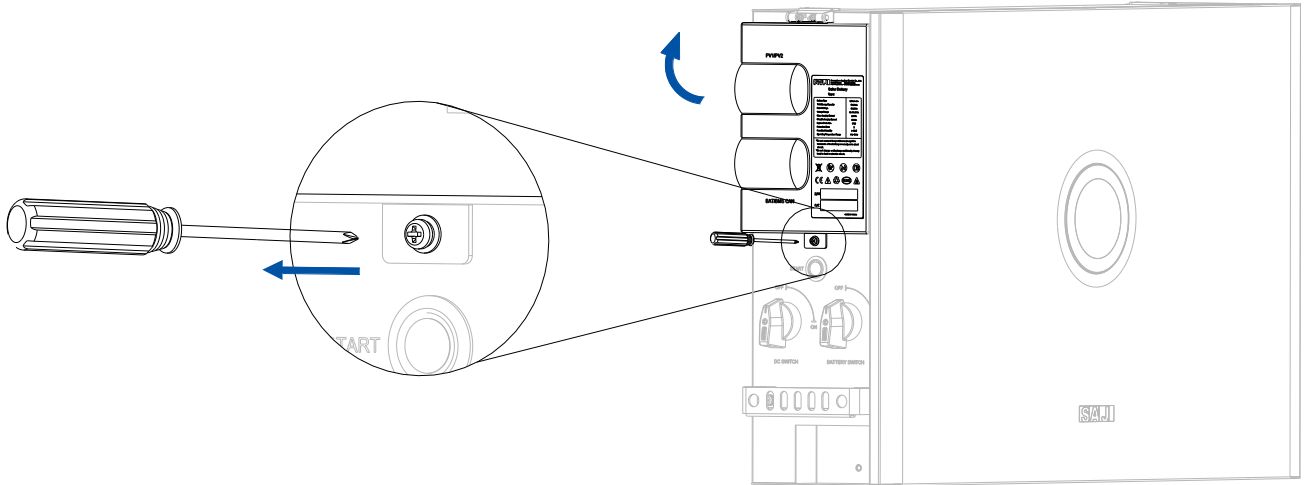

2. Connect the PV cables.

DANGER

- Dangerous to life due to electric shock when live components or DC cables are touched.
- The PV panel string will produce lethal high voltage when exposed to sunlight. Touching live DC cables results in death or lethal injuries.
- DO NOT touch non-insulated parts or cables.

WARNING

- Disconnect the inverter from voltage sources.
- DO NOT disconnect DC connectors under load.
- Wear suitable personal protective equipment for all work.

Recommended cable specification:

| Conductor cross-sectional area of cables (mm ²) | | Conductor material |
|---|-------------------|--|
| Range | Recommended value | Outdoor copper wire cable, complying with 600 V DC |
| 5.0 – 6.0 | 6.0 | |

Before you start, verify that:

- The PV array is properly insulated to ground before it is connected to the inverter. The inverter cannot be used with functionally earthed PV arrays.
- The DC switch on the inverter is in OFF position to avoid short circuit caused by maloperations.
(For Australia) To comply with local regulations and for further safety consideration, use a reliable tool (such as a lock with a key) to lock the switch, so that others cannot unlock it easily.

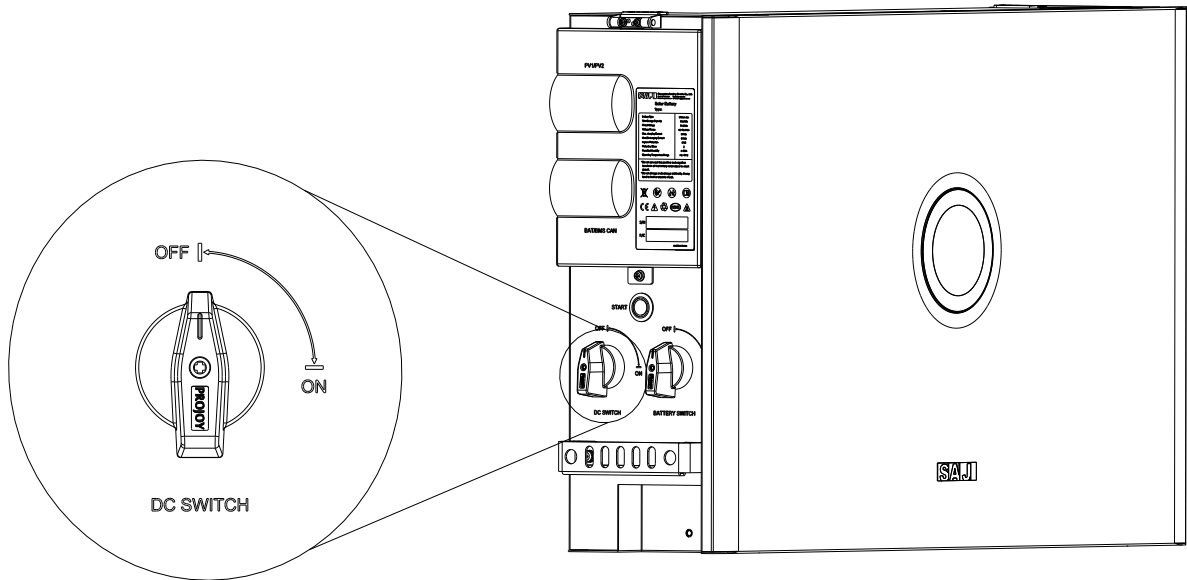

- a. Use a 3-mm wide-bladed screwdriver to strip the insulation layer around 8 to 10 mm length from one end of each cable.

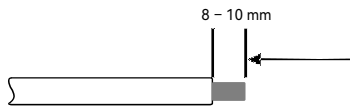

- b. Insert the cable ends to the sleeves. Use a crimping plier to assembly the cable ends.

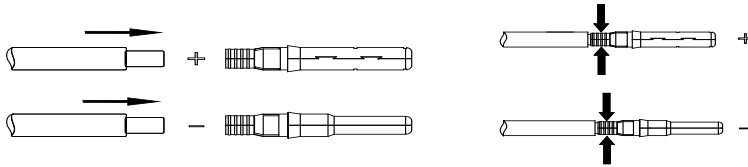

- c. Insert the assembled cable ends into the blue positive and negative PV connectors. Gently pull the cables backwards to ensure firm connection.

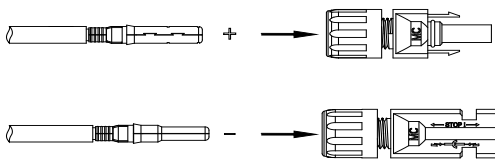

- d. Tighten the lock screws on the positive and negative cable connectors.

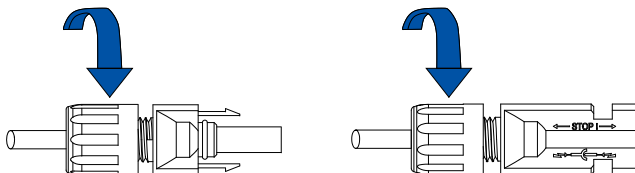

- e. Insert the positive and negative cable connectors into the positive and negative PV ports on the inverter until you hear a “click” sound to ensure firm connection.

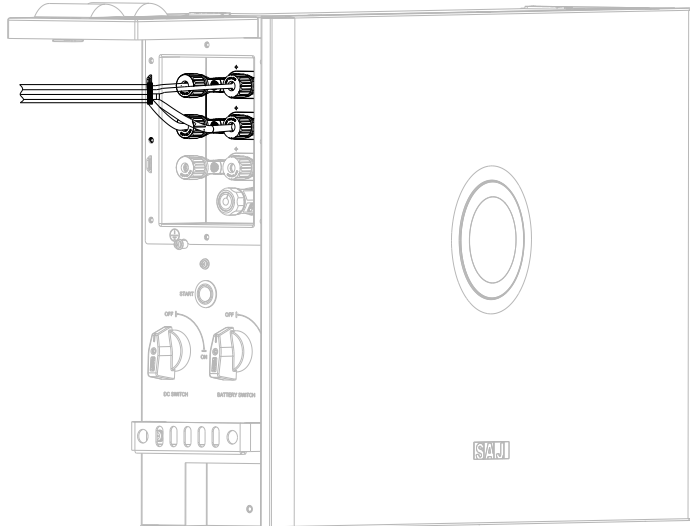
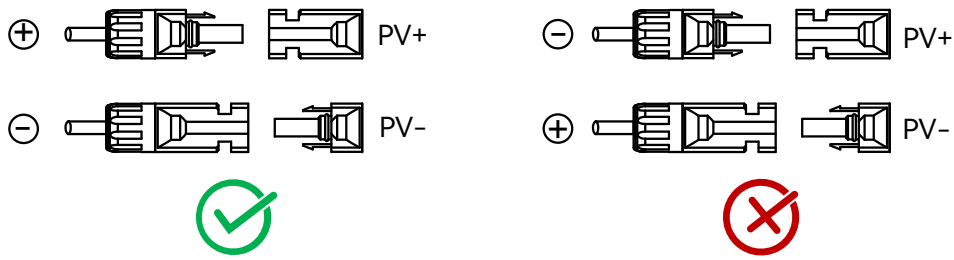

- 3. (Optional) Connect the battery cables between multiple stacks.
 - a. Prepare and connect the grounding cable to the battery combiner box.

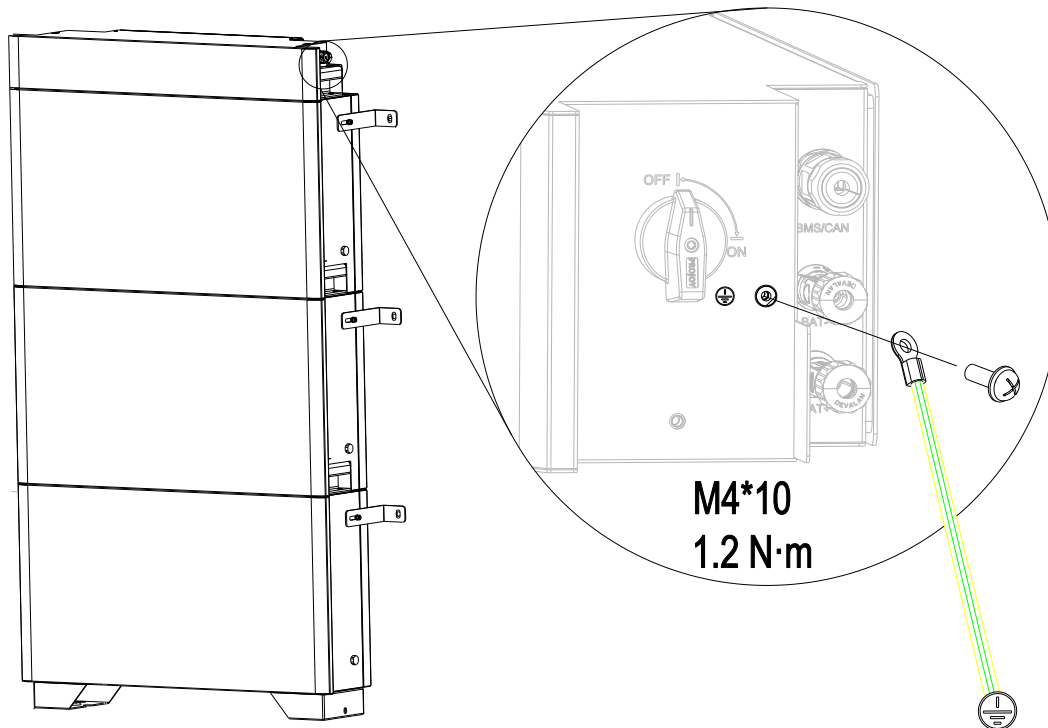

- b. Use the positive and negative power cables and the communication cable that are shipped with the battery combiner box. Connect the cables from the combiner box to the inverter, as listed below:

| Cable | From the combiner box | To the inverter |
|------------------------------------|-----------------------|---------------------|
| Positive and negative power cables | BAT+ and BAT- ports | BAT+ and BAT- ports |
| Communication cable | BMS/CAN port | BMS CAN port |

Notes:

- The BMS/CAN port on the inverter has been installed with an RJ45 connector plug. In this case, remove this plug and insert it into the BMS/CAN port on the battery combiner box on the left stack.
- The provided cables have been assembled with connectors. In some special cases, if you need to use your own cables, contact SAJ for technical support.

Taking 8 batteries connecting to one inverter as an example:

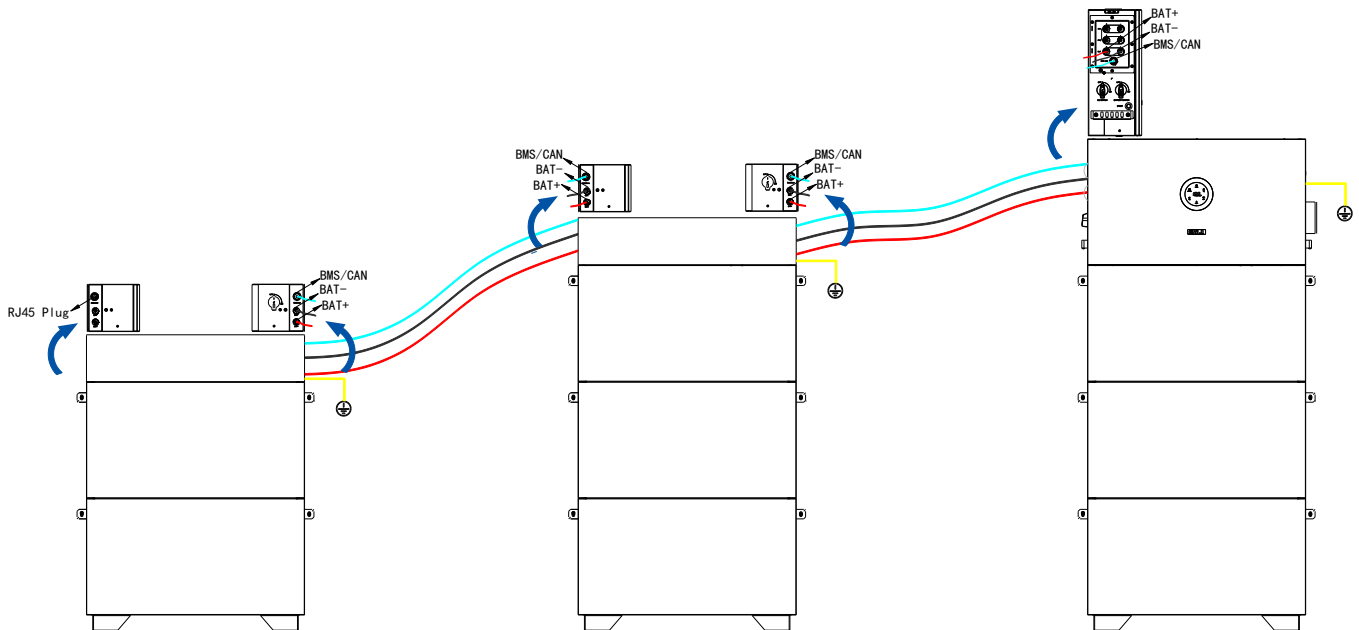

4. Close the DC-side cover.



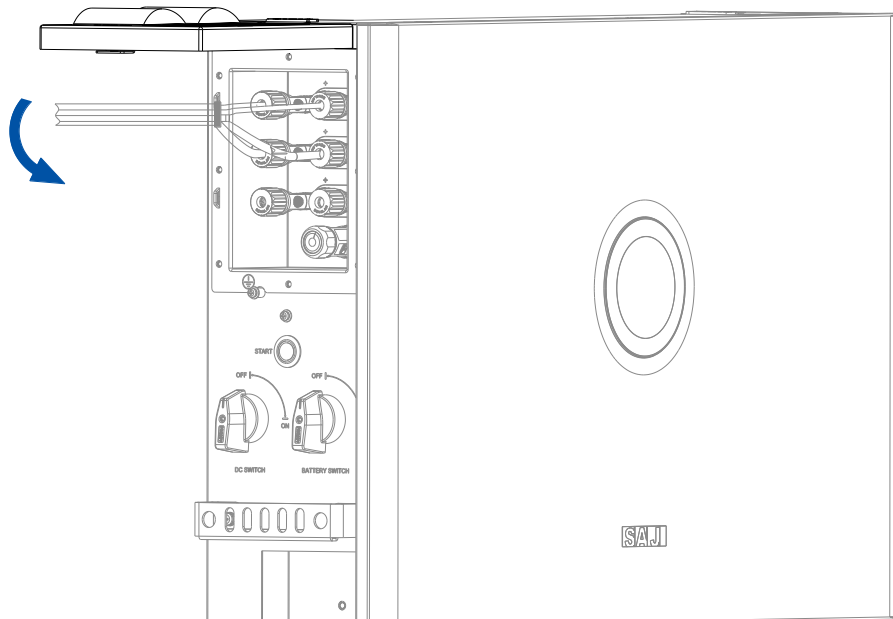

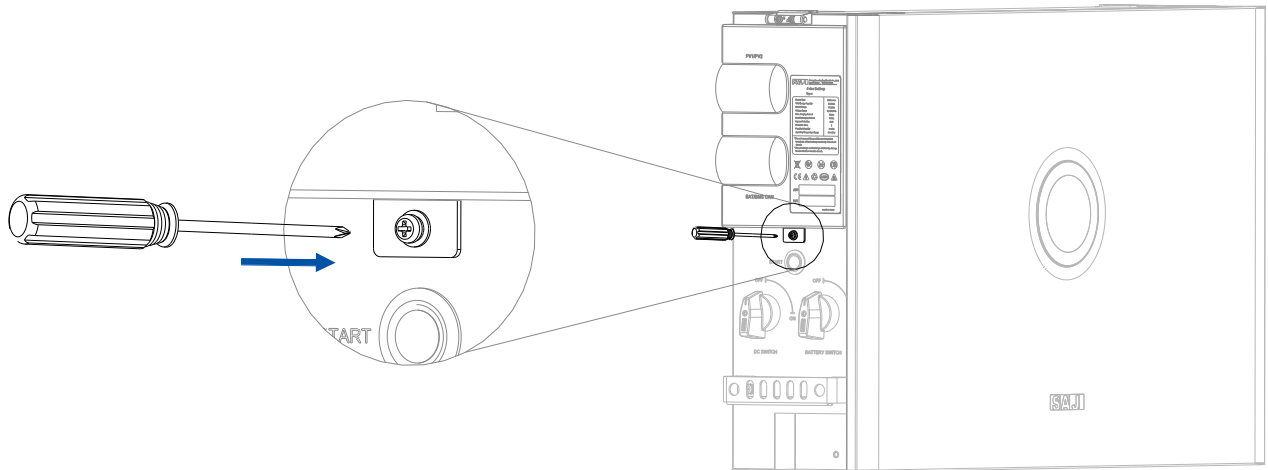



Push the cover downwards. Use a screwdriver to tighten the screw to lock the cover securely.







□ 10. Start the system

1. (Optional) If there are multiple battery stacks, turn on the battery switch on the right side of the battery combiner box.
2. On the left side of the inverter, perform as follows:
 - a. Turn on BATTERY SWITCH.
 - b. Turn on DC SWITCH.
 - c. Press and hold the START button for two or three seconds until the LED indicator on the front panel is on .
3. Check the LED indicator status on the inverter panel to ensure that the inverter is running properly.

| LED indicator | Status | Description |
|--|-----------------------|---|
|  | Off | The inverter is powered off. |
|  | Breathing 6s | The inverter is in initialization or standby state. |
|  | Solid on | The inverter is working properly. |
|  | Breathing 3s | The inverter is upgrading. |
|  | Solid on | The inverter is not working properly. |
| | Integer (example, 50) | Battery average SOC (for example, 50%) |
| | -- | The battery communication is lost. |
|  BATTERY | Solid on | The battery is working properly. |
| | On 1s, off 1s | The battery is not working properly. |
| | Off | The battery is disconnected or inactive. |
|  GRID | Solid on | The grid is connected and working properly. |
| | On 1s, off 1s | The grid is not working properly. |
| | Off | No grid is detected. |
|  SOLAR | Solid on | The PV array is working properly. |
| | On 1s, off 1s | The PV array is not working properly. |
| | Off | The PV array is not working. |

| | | |
|---|---------------|--|
|  BACK-UP | Solid on | The AC-side load is working properly. |
| | On 1s, off 1s | The AC-side load is overloaded. |
| | Off | The AC-side load is disconnected or off. |
|  COM | Solid on | In good communication with the meter, BMS, and cloud. |
| | On 1s, off 1s | Lost communication with the meter, BMS, or cloud. |
| | Off | Lost communication with all the meter, the BMS, and cloud. |
|  EV CHARGER | Solid on | The EV charger is in standby mode and working properly. |
| | On 1s, off 3s | The EV charger is charging. |
| | On 1s, off 1s | The EV charger is not working properly. |
| | Off | The EV charger is disconnected. |

4. Configure the system on the SAJ App named Elekeeper. For details, refer to the section “System Commissioning” in the *SAJ Configuration Instructions*.
5. If any error occurs, check the error code displayed on the App. For detailed error messages, refer to the section “Troubleshooting” in the *User Manual*.

---End

Installer: _____